

DOCUMENTACIÓN TÉCNICA

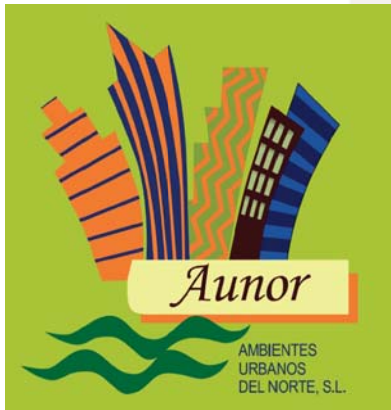

Ref.: T005

Tobogán Quipar

UNE EN 1176-1:2009

UNE EN 1176-3:2009



marca
acreditada
por



Altura de caída: 0,90 m

Edad recomendada de uso: a partir de 3 años

Componentes plásticos: Polietileno de Alta Densidad

Rampa de tobogán: acero inoxidable

Tornillería protegida con tapones de polipropileno

Tubo superior: acero inoxidable

Madera tratada en autoclave Nivel IV

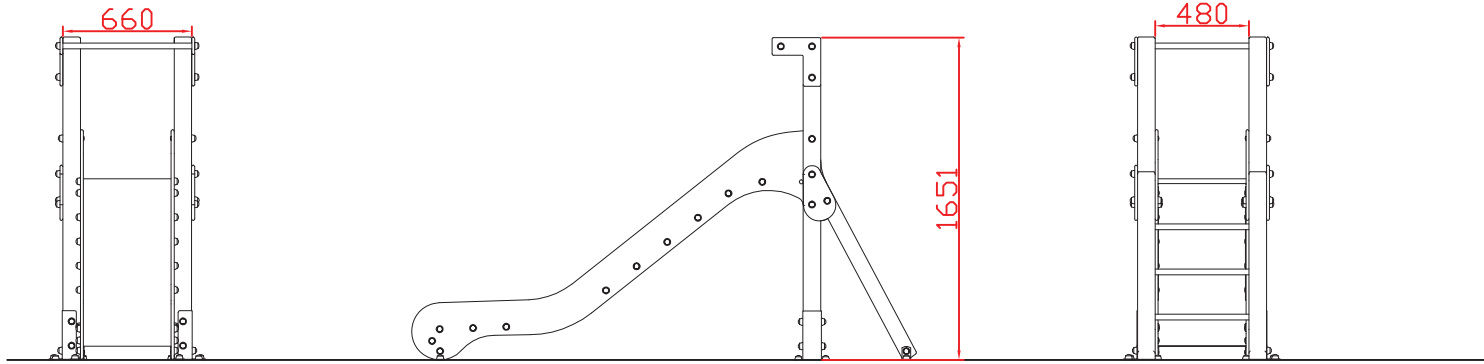

Perfil Izquierdo

Alzado

Perfil Izquierdo

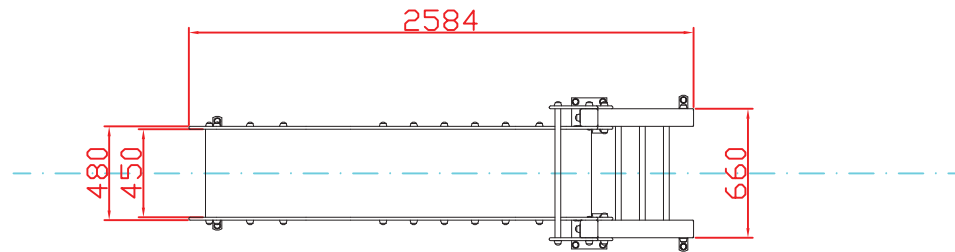



Planta

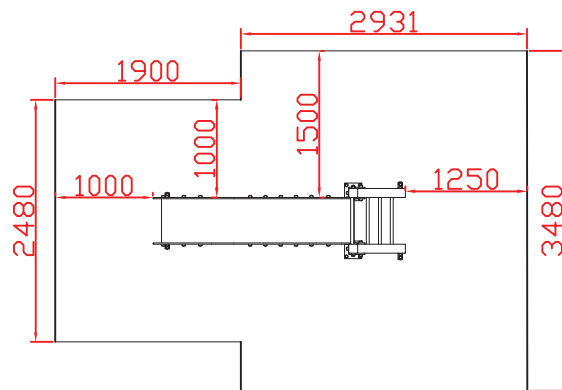

AREA DE SEGURIDAD

Superficie= 14,91 m2
E:1/2



Ref:	Cantidad	Designación	Material	Dimensiones
Dibujado		PLANO 1 VISTAS GENERALES	Ref.: T005	
Revisado				
Aprobado				
Descripción: TOBOGÁN QUIPAR		Escala:	Peso:	
		Fecha:	15-07-15	

ESQUEMA DE CIMENTACIÓN PARA CASOS EN LOS QUE NO VA ATORNILLADO

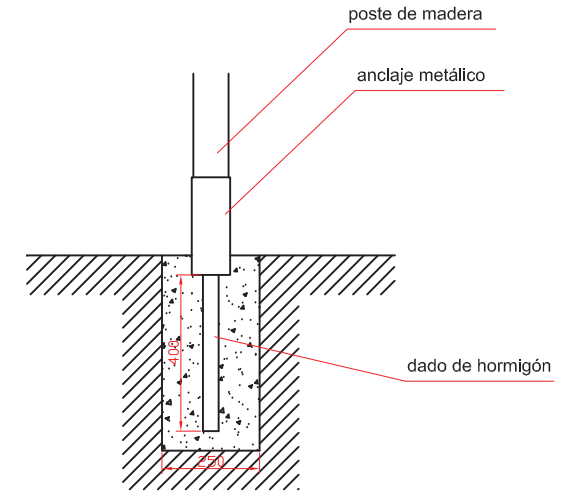
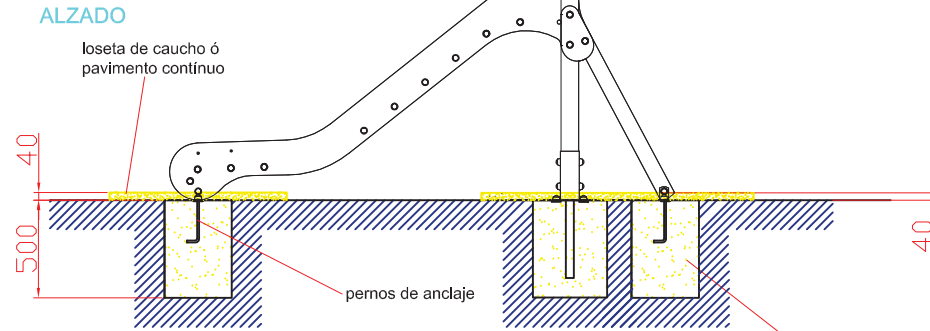

DETALLE DE CIMENTACIÓN

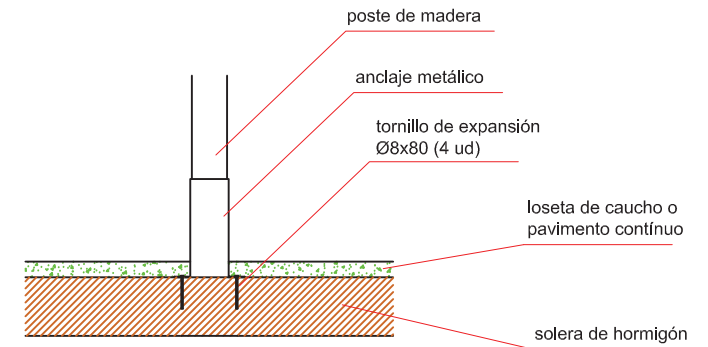
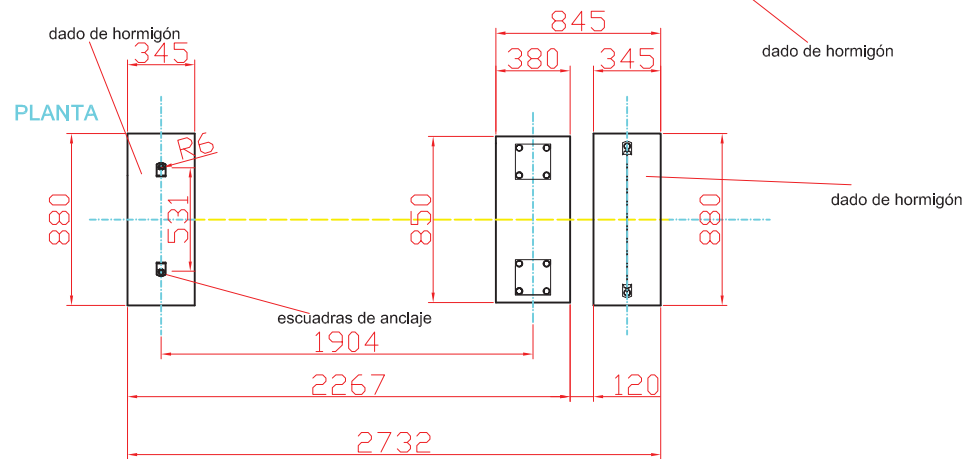

DETALLE DE ANCLAJE ATORNILLADO



Ref:	Cantidad	Designación	Material	Dimensiones
Dibujado		PLANO 2 CIMENTACIÓN ANCLAJES	Ref.: T005	
Revisado				
Aprobado				
Descripción: TOBOGÁN QUIPAR		Escala:	Peso:	
		Fecha:	15-07-15	

