

DOCUMENTACIÓN TÉCNICA

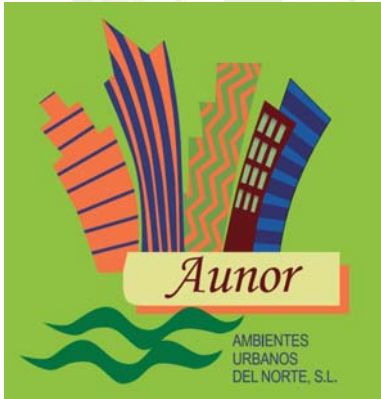

Ref.: TR002

Trepa N°2

UNE EN 1176-1: 2009



marca
acreditada
por



Componentes plásticos: Polietileno de Alta Densidad con protección UV

Edad recomendada de uso: a partir de 3 años

Altura libre de caída: 1,40m

Trepa de cuerda con alma de acero

Tornillería protegida con tapones de polipropileno

Tubos de acero inoxidable

Madera tratada en autoclave Nivel IV

Perfil Derecho

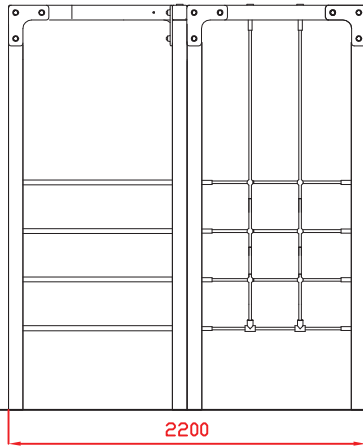

Alzado

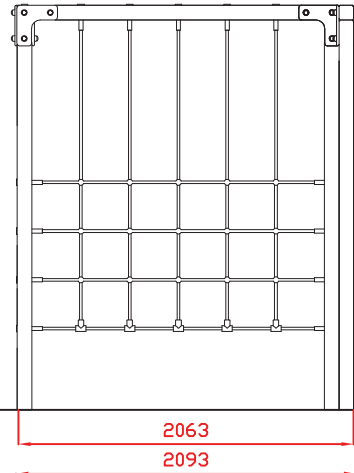

Perfil Izquierdo

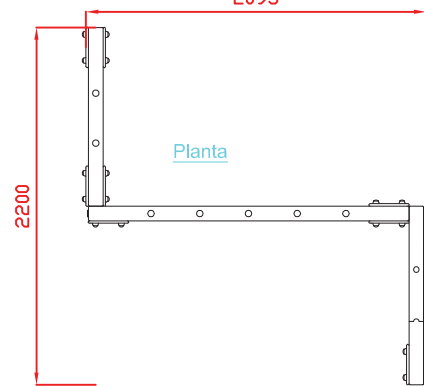
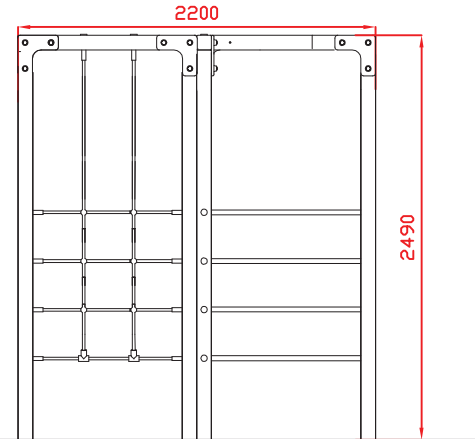

Planta

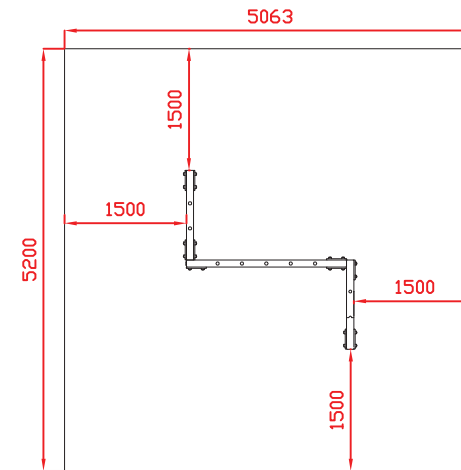

Área de Seguridad

Superficie=26,31m²
E:1/2



Ref:	Cantidad	Designación	Material	Dimensiones
Dibujado		PLANO 1 VISTAS GENERALES	Ref.: TR002	
Revisado				
Aprobado				
Descripción:	TREPA N°2	Escala:	Peso:	
		Fecha:	7-7-15	

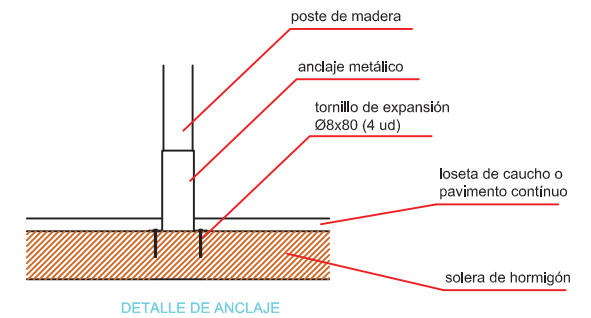
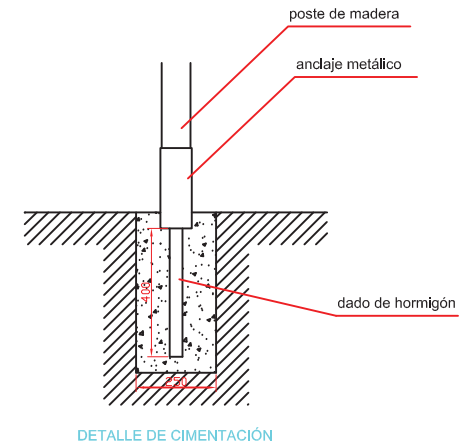
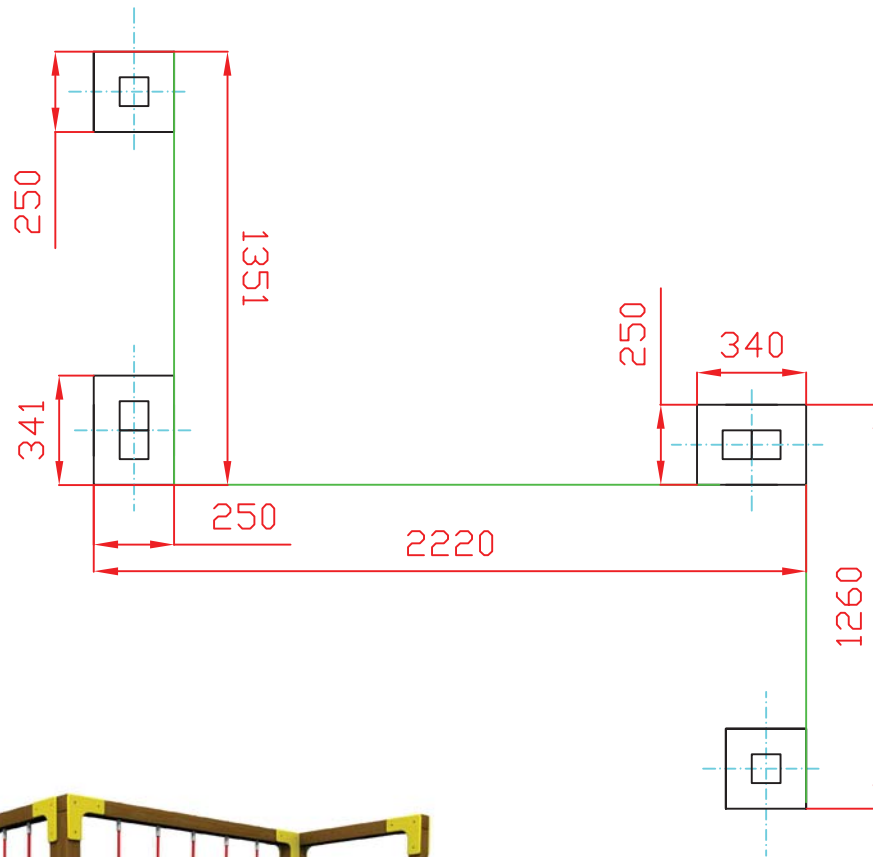

Ref:	Cantidad	Designación	Material	Dimensiones
Dibujado		PLANO 2	Ref.: TR002	
Revisado		CIMENTACIÓN		
Aprobado				
Descripción:	TREPA N°2	Escala:	Peso:	
		Fecha:	7-7-15	

