

DOCUMENTACIÓN TÉCNICA

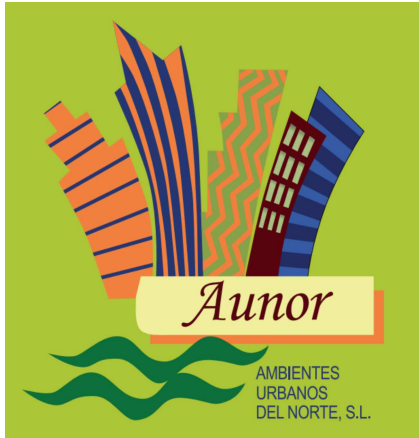

Ref.: BD001

Balancín Doble “Los Ponys”

UNE EN 1176-1:2009

UNE EN 1176-6:2009



marca
acreditada
por



Altura libre de caída: 0,50 m
Edad recomendada de uso: de 3 a 9 años
Muelles con antipinzamiento
Componentes plásticos: Polietileno de Alta Densidad
Componentes metálicos pintados al horno
Madera tratada en autoclave nivel IV
Tornillería protegida con tapones de polipropileno

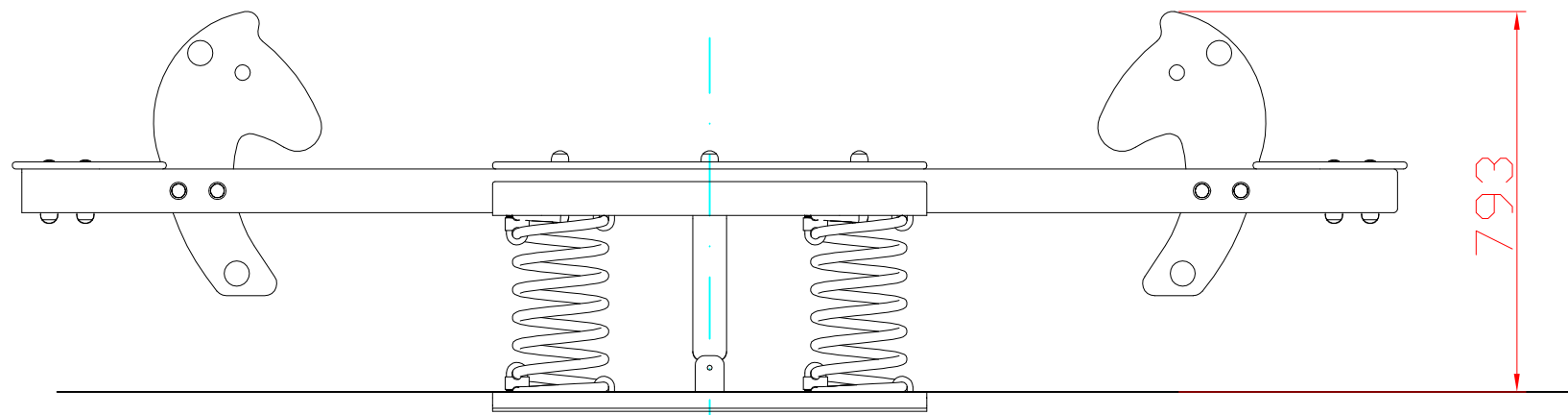

Alzado

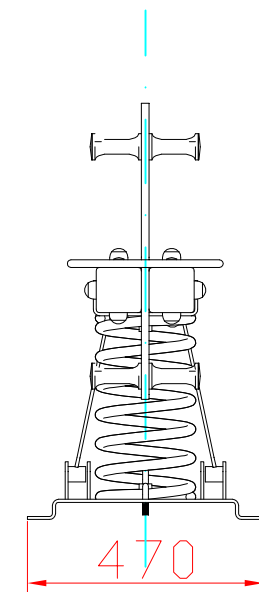

Perfil

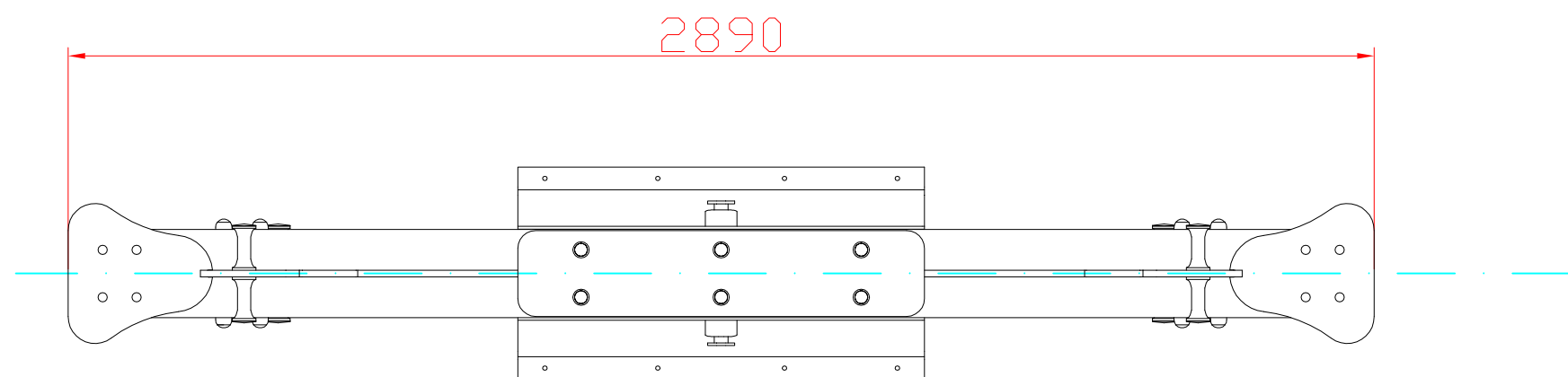

Planta

Vista perspectiva

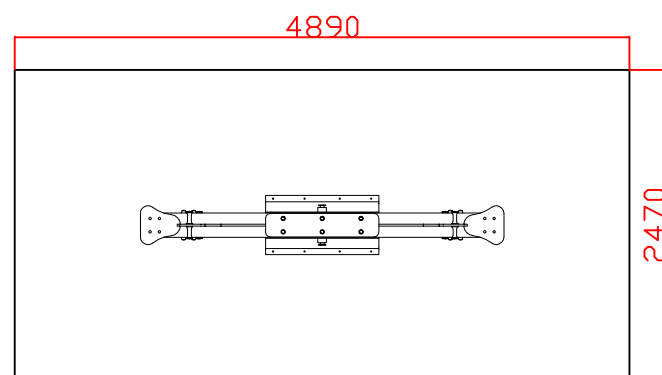
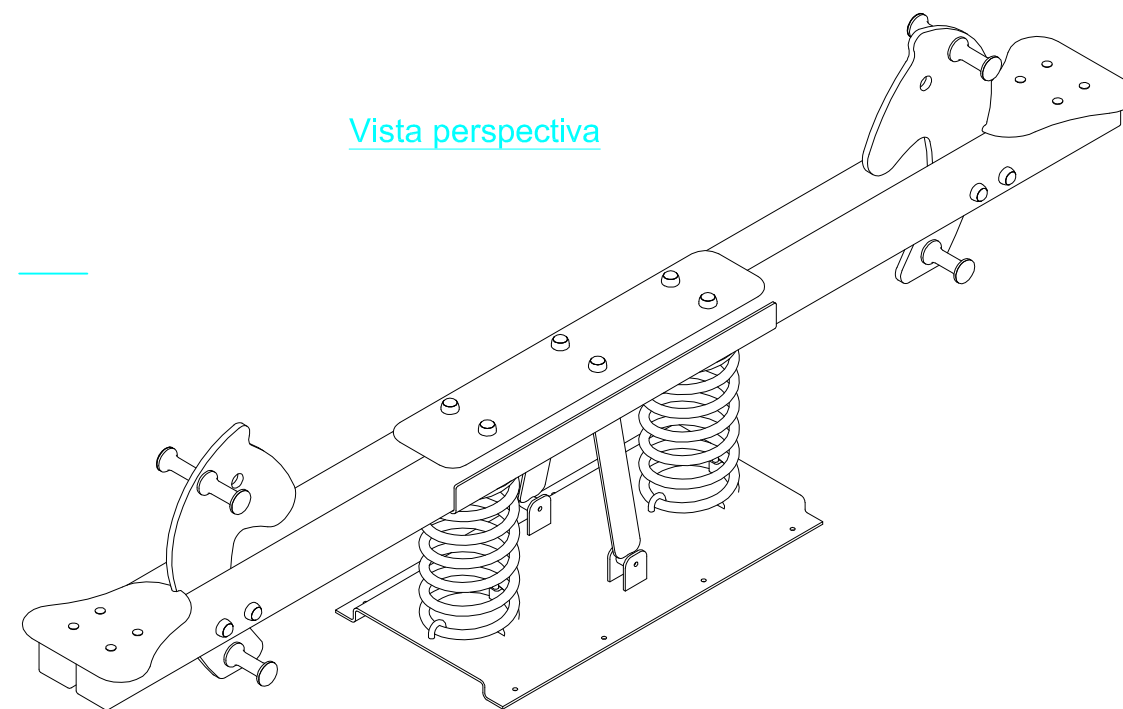

AREA DE SEGURIDAD

Superficie= 12,5 m2
E:1/4

Ref:	Cantidad	Designación	Material	Dimensiones
Dibujado		PLANO 1 VISTAS GENERALES	Ref.:BD001	
Revisado				
Aprobado				
Descripción: BALANCIN DOBLE "LOS PONYS"		Escala:	Peso:	
		Fecha: 28-07-15		



DETALLE DE CIMENTACIÓN

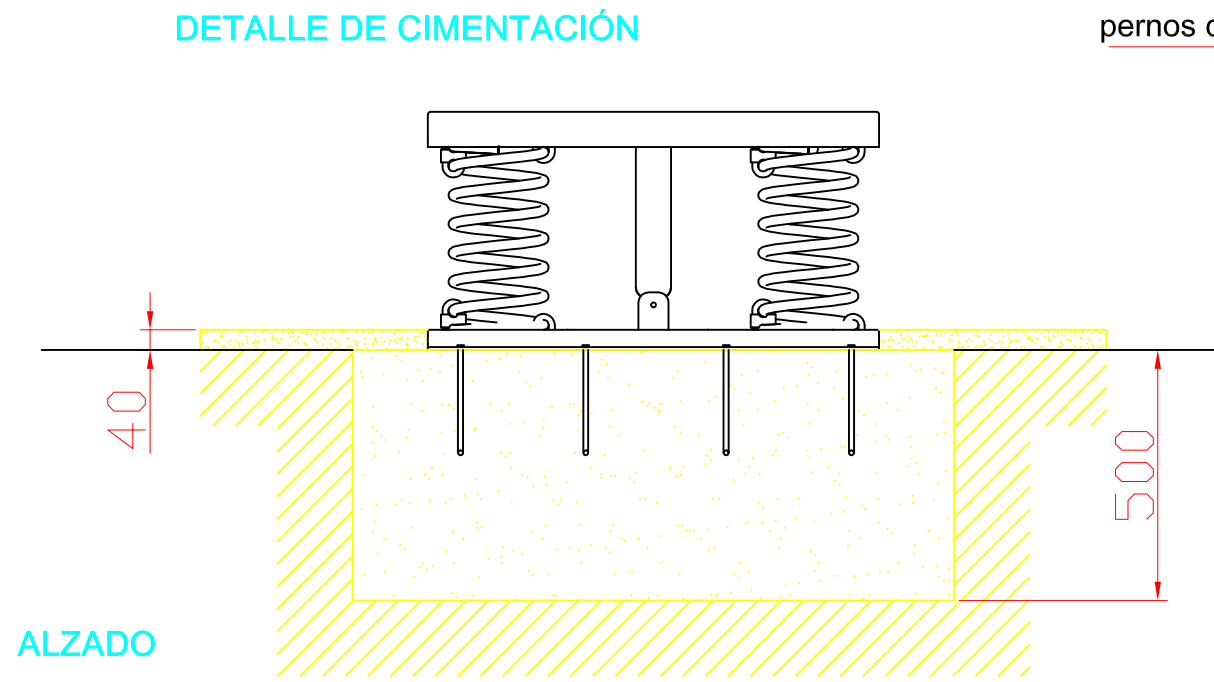

ALZADO

pernos de anclaje

loseta de caucho ó pavimento continuo

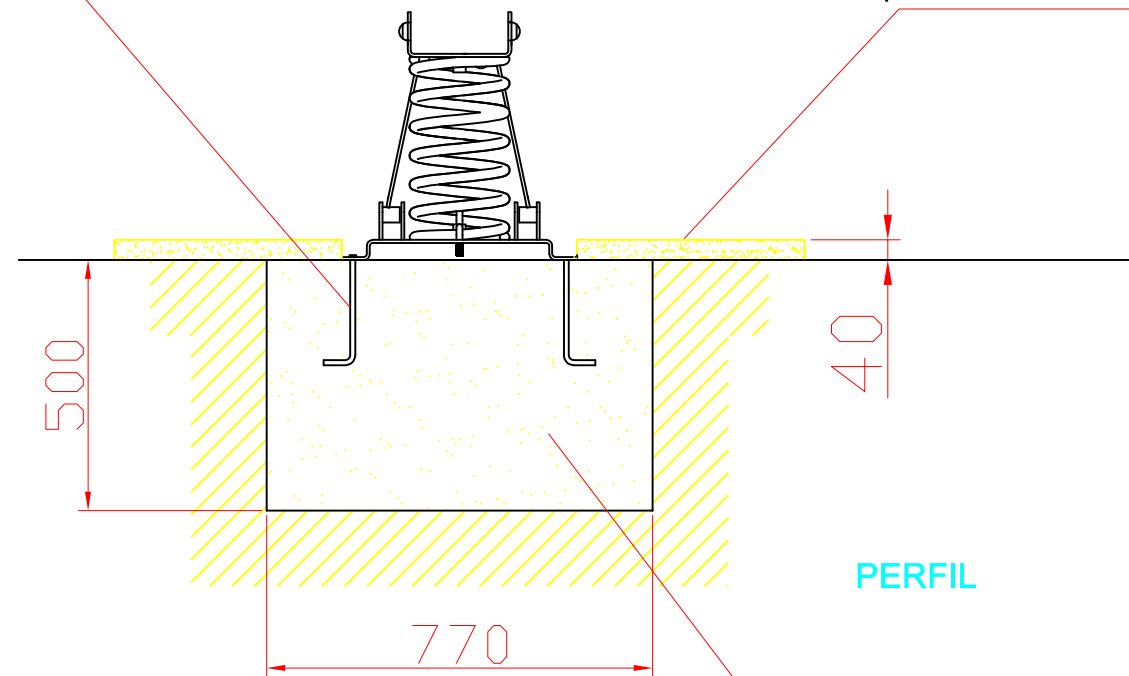

PERFIL

dado de hormigón

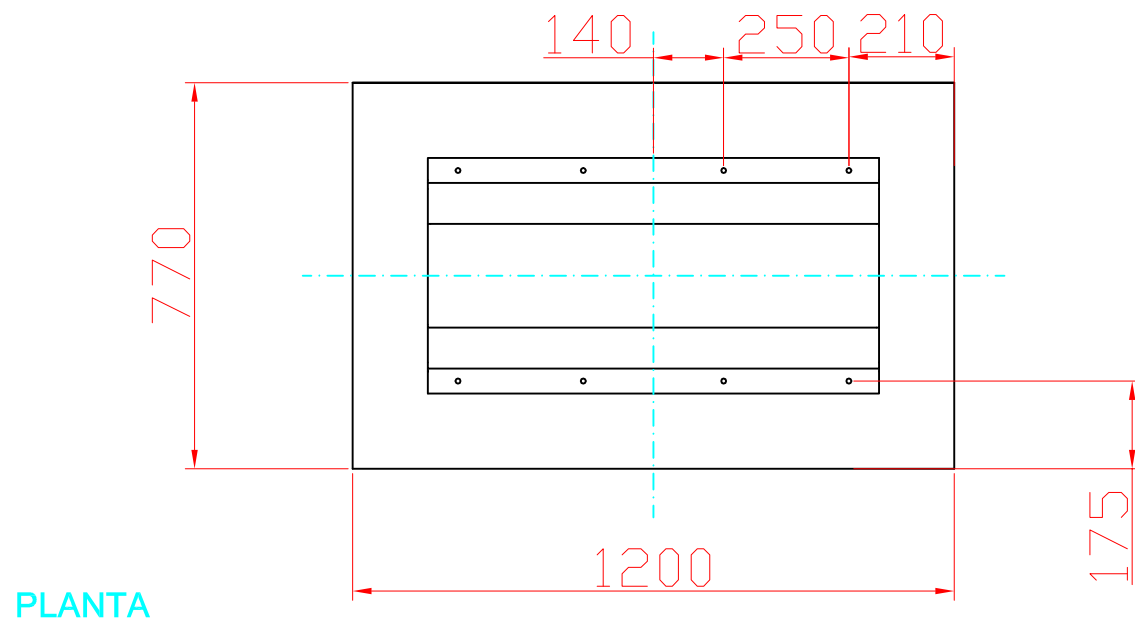

PLANTA

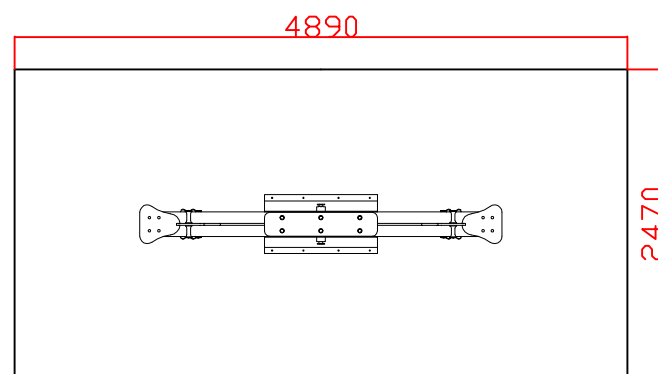

AREA DE SEGURIDAD

Superficie= 12,5 m2
E:1/4

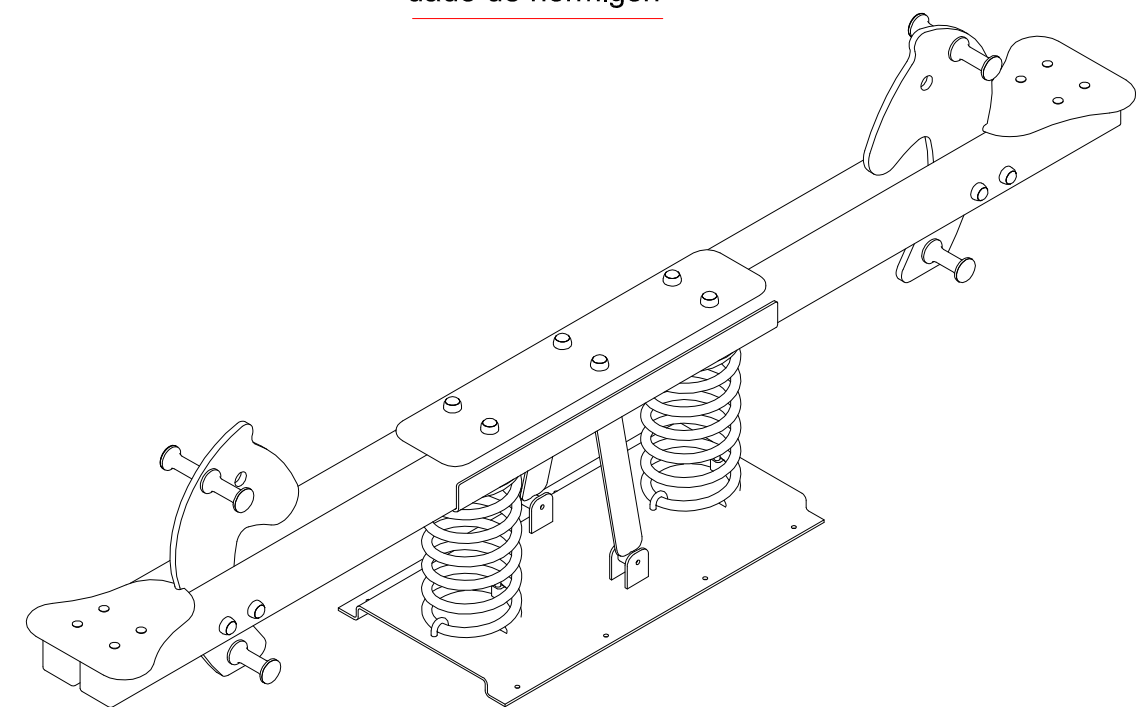

Ref:	Cantidad	Designación	Material	Dimensiones
Dibujado		PLANO 2	Ref.:BD001	
Revisado		PLANO DE CIMENTACIÓN		
Aprobado				
Descripción: BALANCIN DOBLE "LOS PONYS"		Escala:	Peso:	
		Fecha:	28-07-15	

