

DOCUMENTACIÓN TÉCNICA

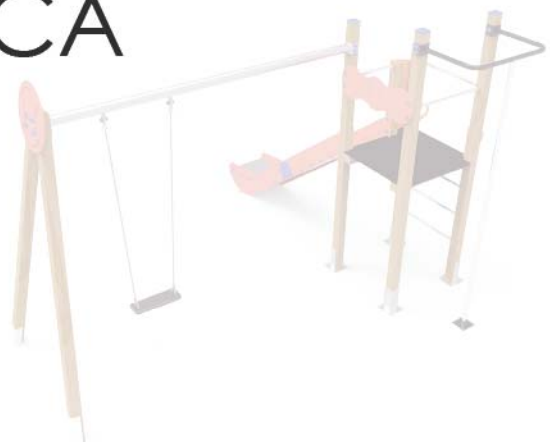

Ref.: SPT02

Maxi Torre "BEISBOL"

UNE EN 1176-1:2018

UNE EN 1176-2:2018

UNE EN 1176-3:2018



Altura libre de caída: 1,36 m
Edad recomendada de uso: a partir de 3 años
Madera de pino tratada en autoclave Nivel IV
Componentes plásticos: Polietileno de alta densidad con protección UV
Componentes metálicos galvanizados
Tobogán con rampa de acero inoxidable
Tubos de barrera de acero inoxidable

ALZADO

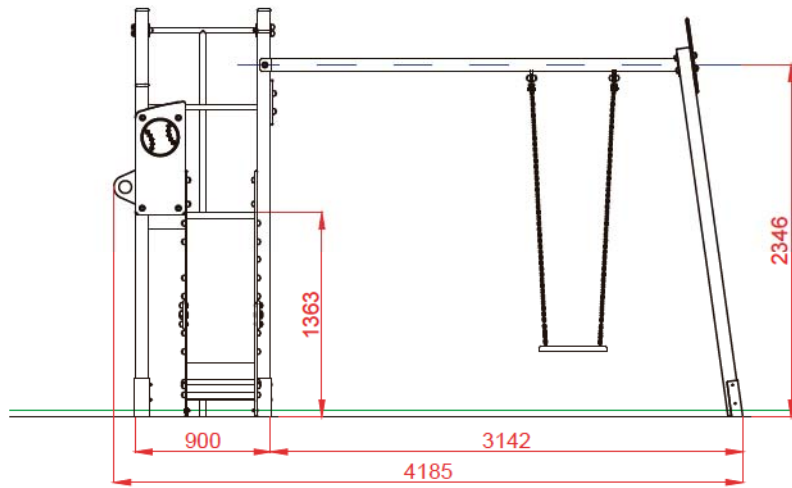

PERFIL IZQUIERDO

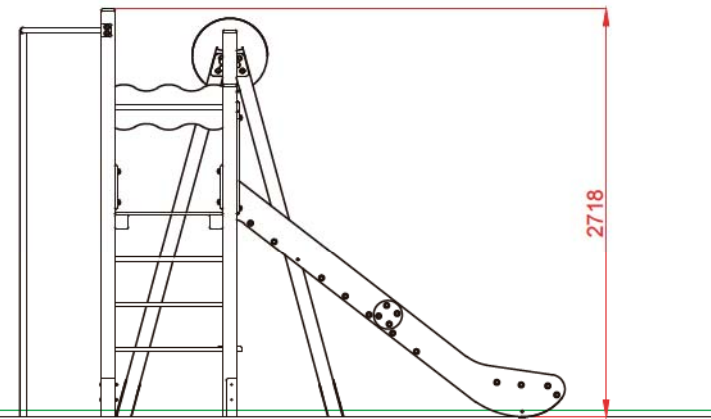

PLANTA

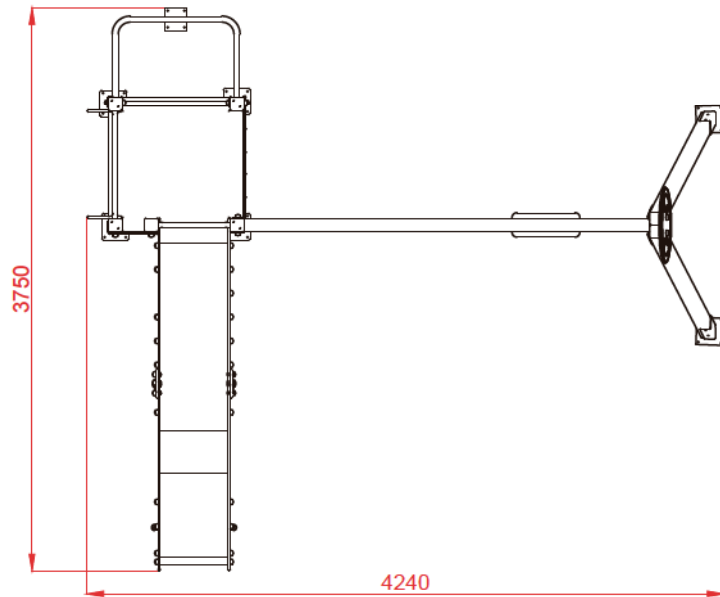

ÁREA DE SEGURIDAD
Superficie= 34,58 m2
E: 1/2

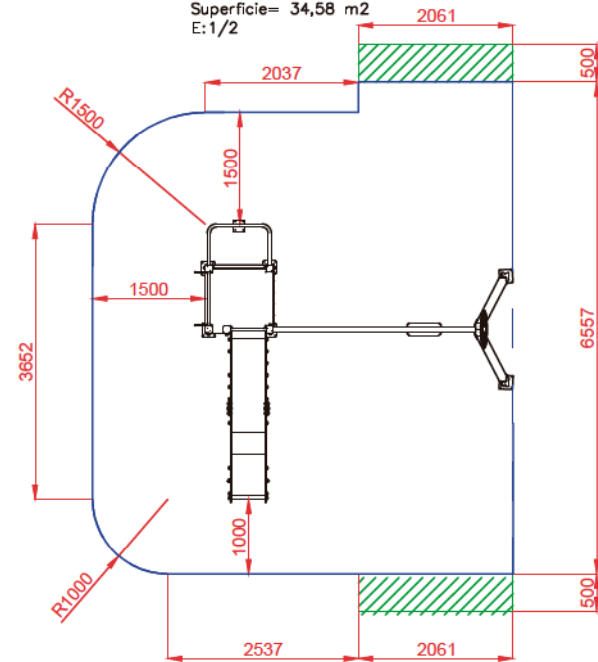

Dibujado		PLANO 1 VISTAS GENERALES	Ref:	SPT02
Revisado				
Aprobado				
Descripción:	MAXI TORRE "BEISBOL"	Escala:	Nº Hoja 2/4	
		Fecha:	19/07/2019	

DETALLES CIMENTACIÓN
 ESQUEMA DE CIMENTACIÓN
 EN ARENA

E: 2/1

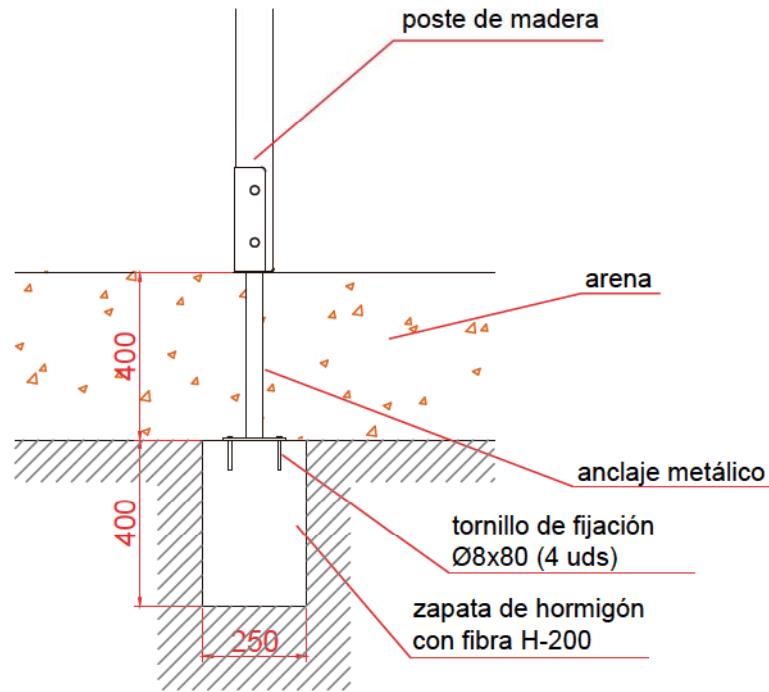

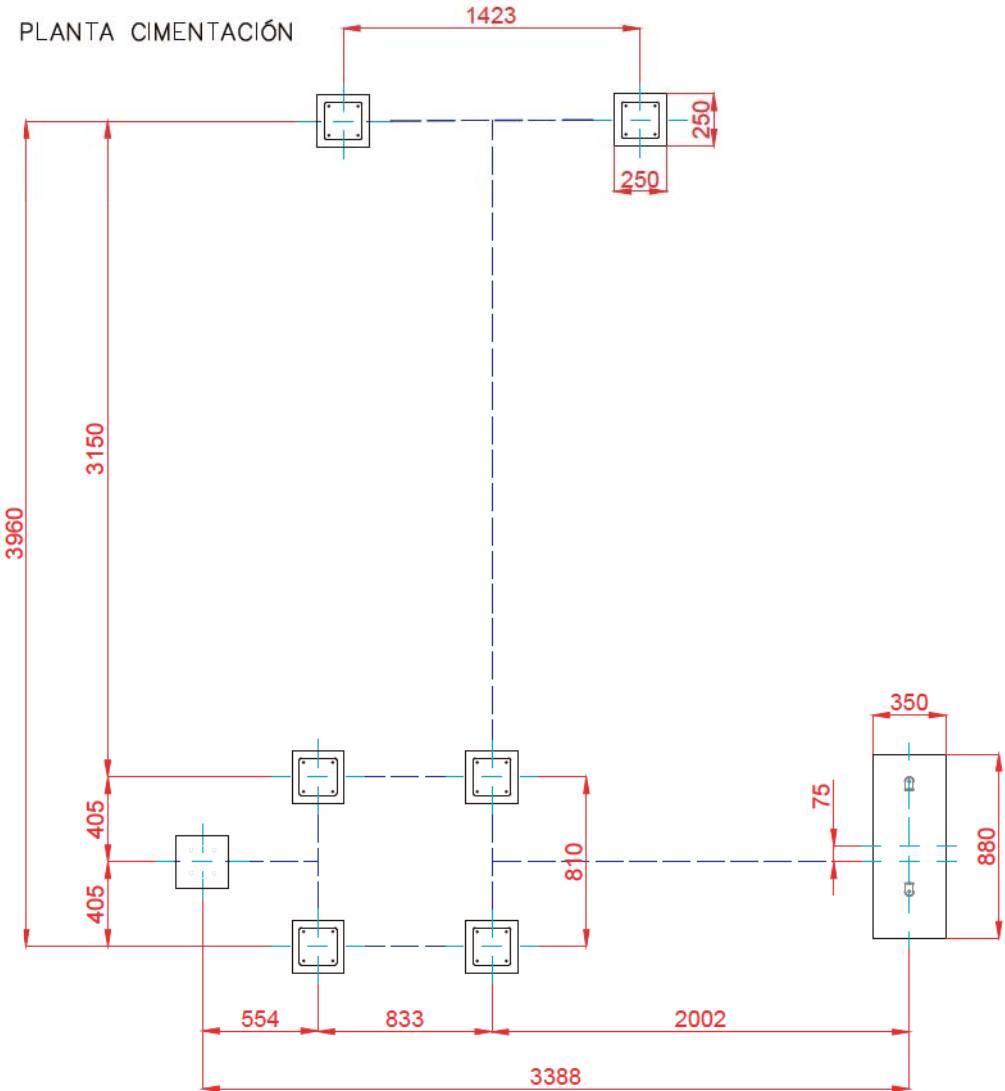
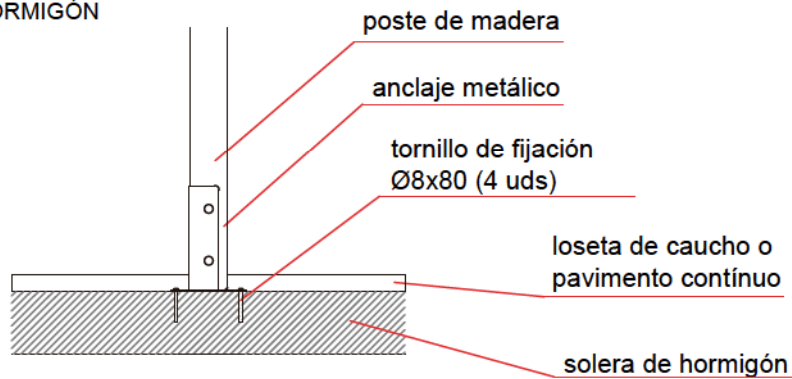

ESQUEMA DE CIMENTACIÓN
 EN HORMIGÓN

E: 2/1

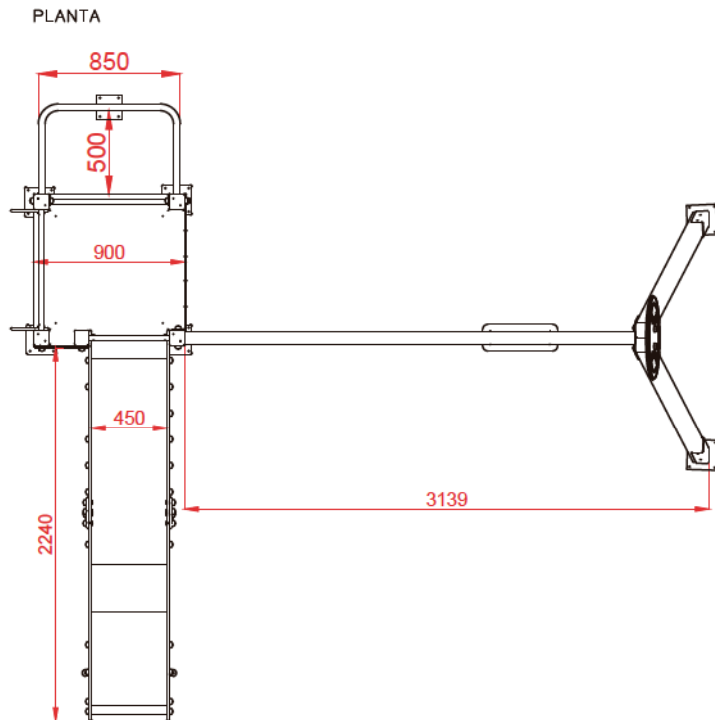
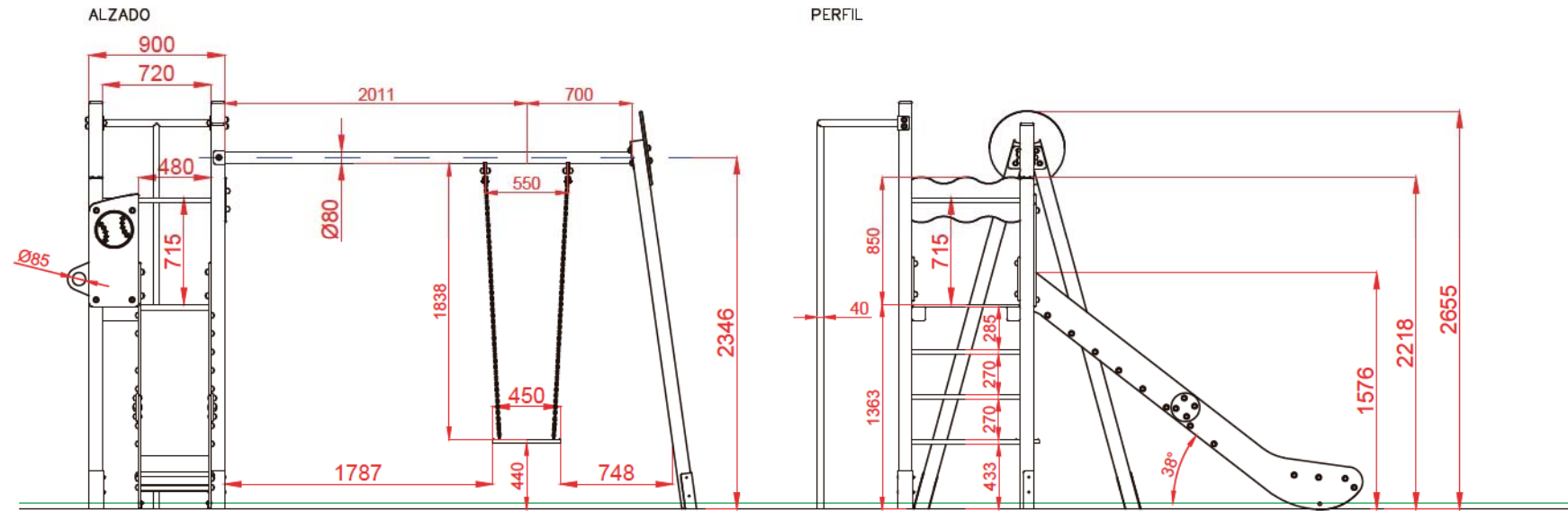

Dibujado		PLANO 2 CIMENTACIÓN Y ANCLAJES	Ref:	SPT02
Revisado				
Aprobado				
Descripción:		MAXI TORRE "BEISBOL"	Escala:	Nº Hoja 3/4
			Fecha:	19/07/2019



Dibujado		PLANO 3 VISTAS DE DETALLE	Ref:	SPT02
Revisado				
Aprobado				
Descripción:		MAXI TORRE "BEISBOL"	Escala:	Nº Hoja 4/4
			Fecha:	19/07/2019