

DOCUMENTACIÓN TÉCNICA



Ref.: CM020

Conjunto "Navia"

UNE EN 1176-1:2009

UNE EN 1176-3:2009



Altura libre de caída: 1,36 m

Edad recomendada de uso: a partir de 3 años

Madera de pino tratada en autoclave Nivel IV

Componentes plásticos: Polietileno de Alta Densidad con protección UV

Componentes metálicos galvanizados

Barra de bomberos y rampa tobogán de acero inoxidable

Trepa de cuerda con alma de acero

Tubos de barrera de acero inoxidable

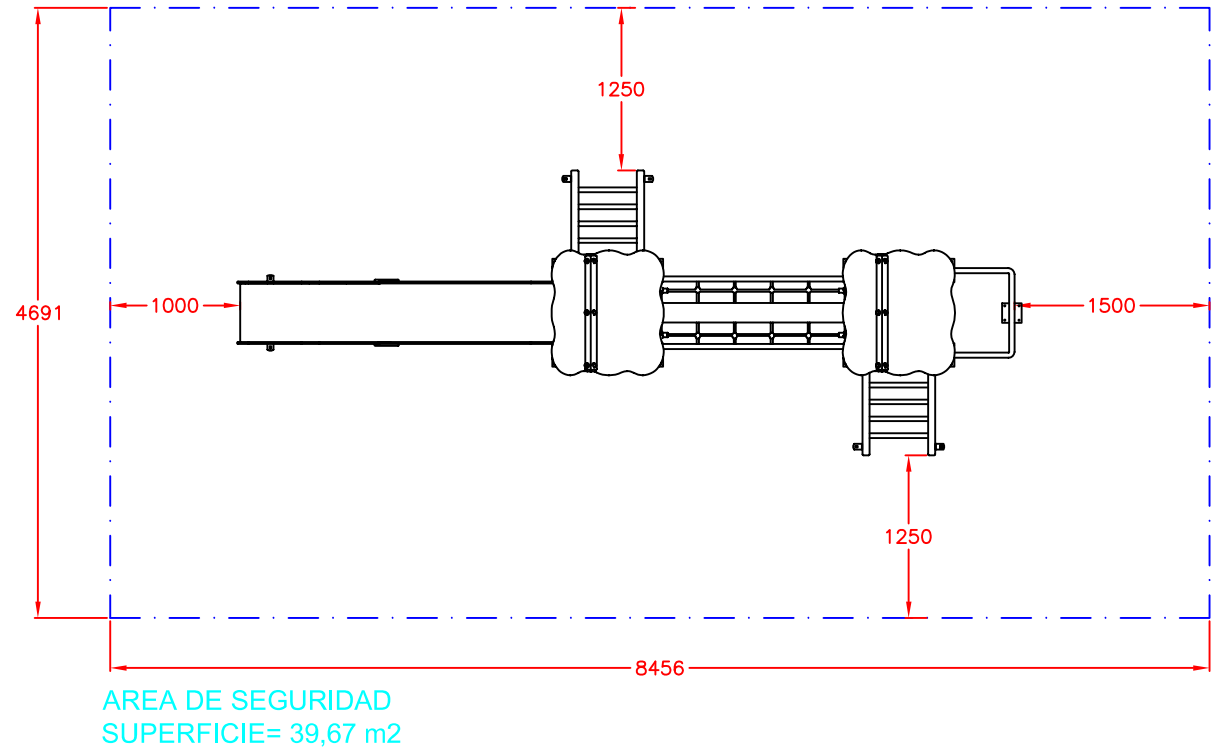
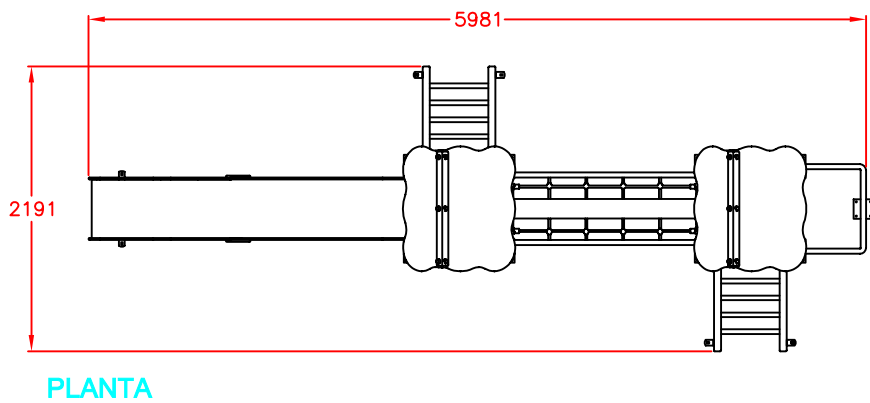
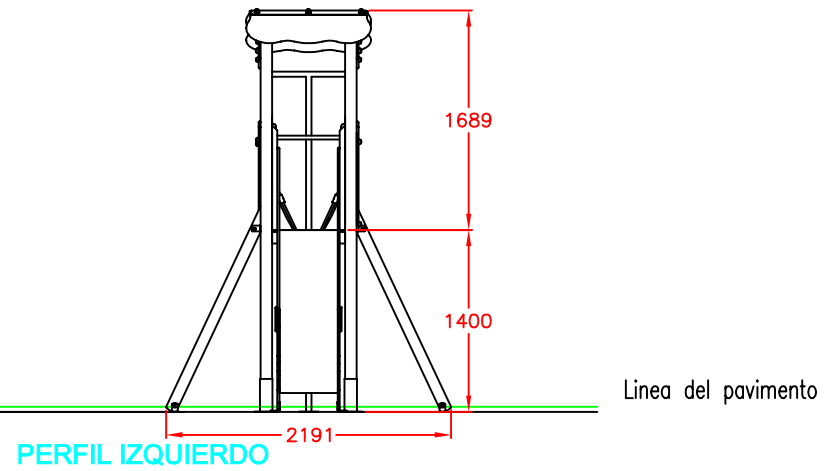
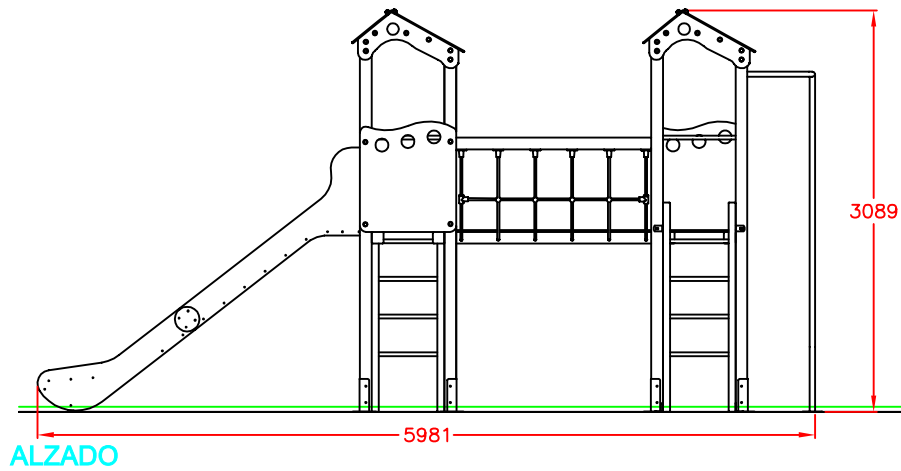

Ref:	Cantidad	Designación	Material	Dimensiones
Dibujado		PLANO 1 VISTAS GENERALES	Ref: CM020	
Revisado				
Aprobado				
Descripción:		Escala:	Peso:	
CONJUNTO "NAVIA"		Fecha: 13-04-16		

ESQUEMA DE CIMENTACIÓN PARA CASOS EN LOS QUE VA EN ARENERO E:2/1

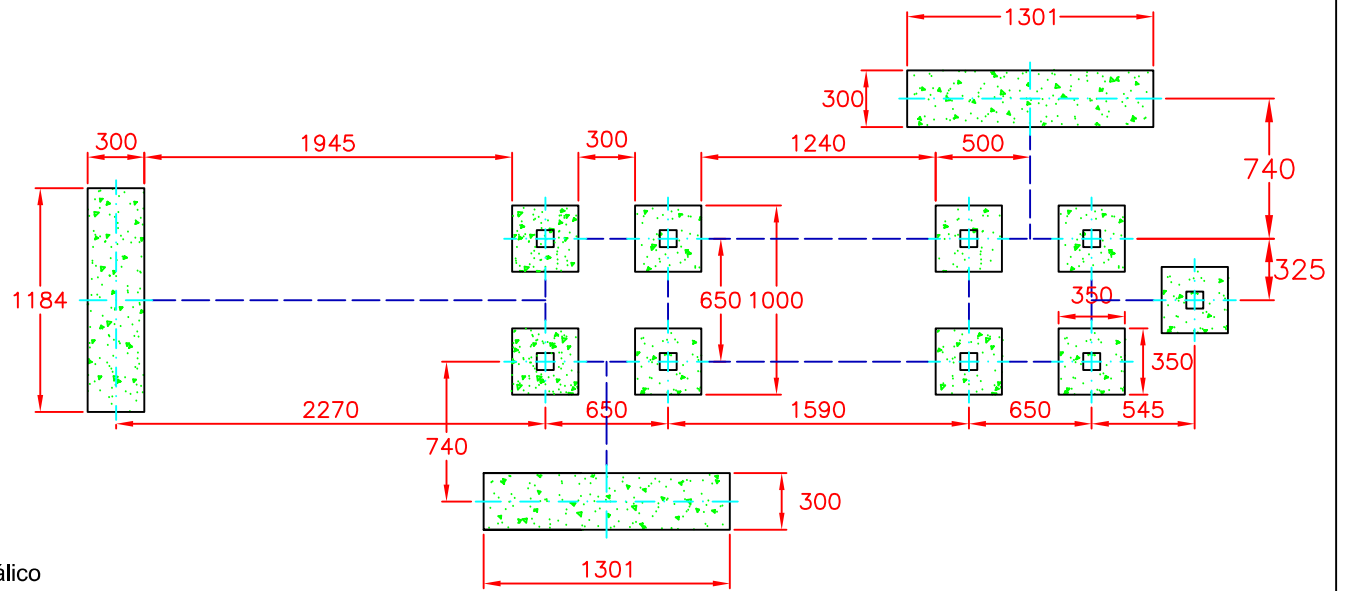
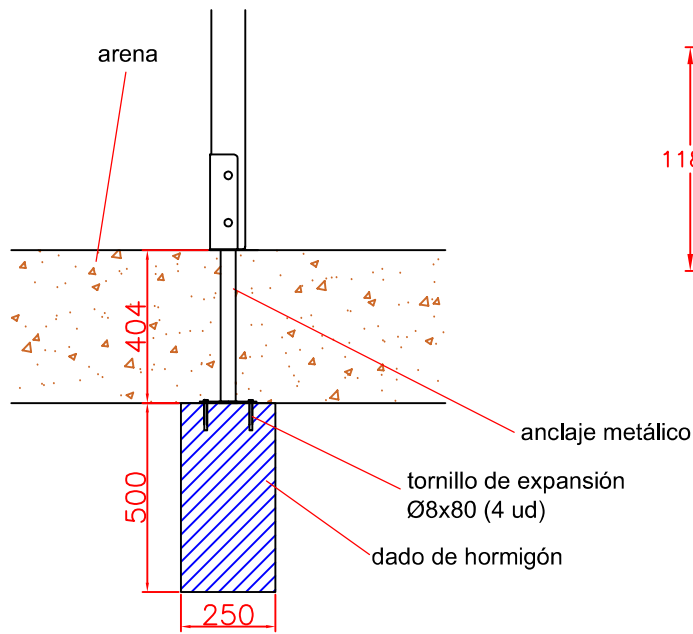

ESQUEMA DE CIMENTACIÓN PARA CASOS EN LOS QUE VA ATORNILLADO SOBRE SOLERA DE HORMIGÓN E:2/1

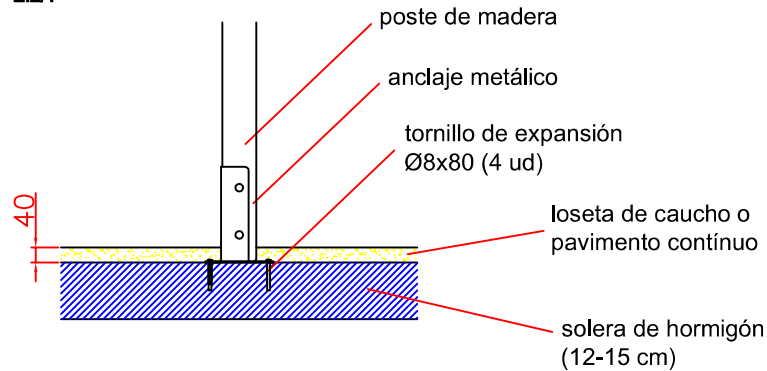

Ref:	Cantidad	Designación	Material	Dimensiones
Dibujado		PLANO 2 CIMENTACIÓN Y ANCLAJES	Ref: CM020	
Revisado				
Aprobado				
Descripción:		Escala:	Peso:	
CONJUNTO "NAVIA"		Fecha: 13-04-16		