

DOCUMENTACIÓN TÉCNICA



Ref.: CM017

Conjunto Segura Mini

UNE EN 1176-1: 2009

UNE EN 1176-3: 2009



marca
acreditada
por



Altura libre de caída: 0,90 m

Edad recomendada de uso: a partir de 2 años

Componentes plásticos: Polietileno de Alta Densidad

Peldaños, Barreras metálicas y Rampa de tobogán: acero inoxidable

Tornillería protegida con tapones de polipropileno

Tubos y cadenas de acero galvanizado

Madera tratada en autoclave Nivel IV

ALZADO

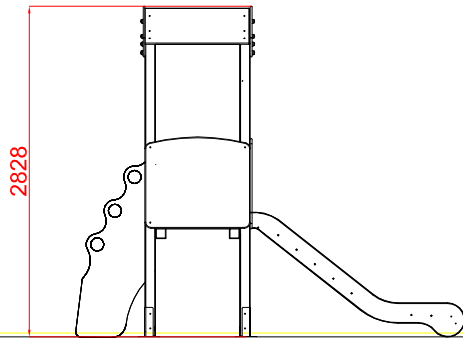

PERFIL DERECHO

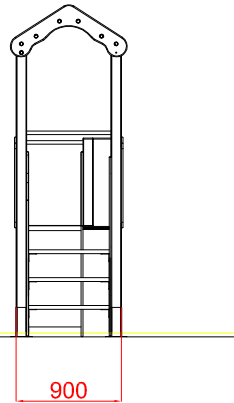

PLANTA

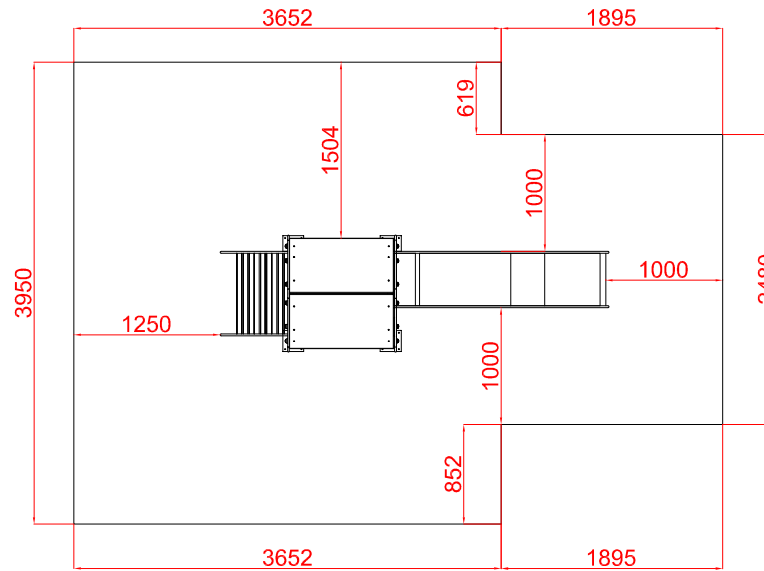
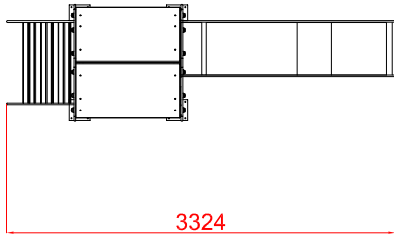

AREA DE SEGURIDAD= 19,12 M2

Ref:CM017	Cantidad	Designación	Material	Dimensiones
Dibujado		PLANO 1 VISTAS GENERALES	Ref.: CM017	
Revisado				
Aprobado				
Descripción: CONJUNTO "SEGURA MINI"		Escala:	Peso:	
		Fecha: 29/07/15		

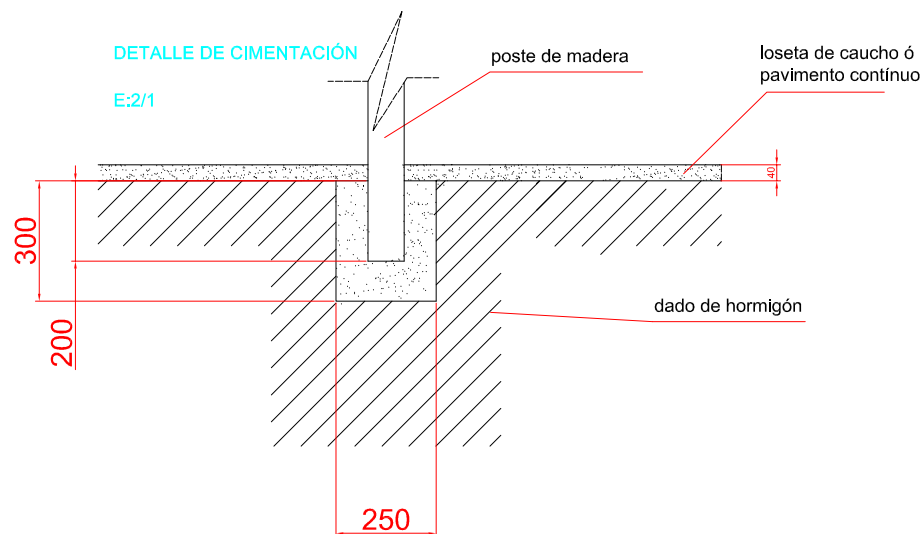
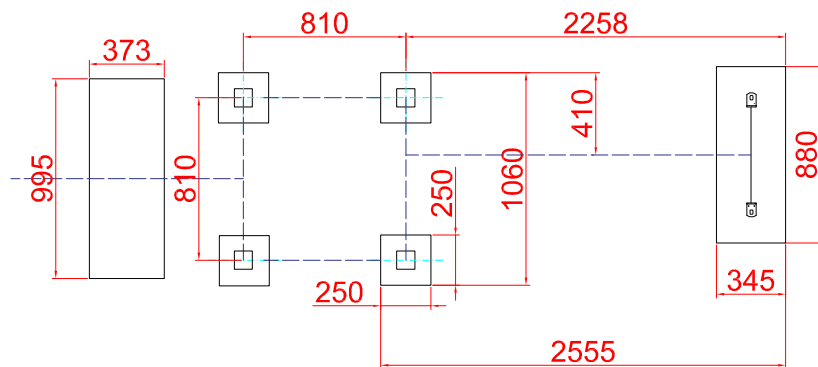

Ref:CM017	Cantidad	Designación	Material	Dimensiones
Dibujado		PLANO 2 CIMENTACIÓN	Ref.: CM017	
Revisado				
Aprobado				
Descripción: CONJUNTO "SEGURA MINI"		Escala:	Peso:	
		Fecha: 29/07/15		