

# DOCUMENTACIÓN TÉCNICA



Ref.: TT003

## Torre Gredos Alta

UNE EN 1176-1:2009

UNE EN 1176-3:2009



Altura de caída: 1,36 m

Edad recomendada de uso: a partir de 3 años

Componentes plásticos: Polietileno de Alta Densidad con protección UV

Rampa de tobogán: acero inoxidable

Tornillería protegida con tapones de polipropileno

Tubo superior: acero inoxidable

Madera tratada en autoclave Nivel IV



marca  
acreditada  
por



Perfil Derecho

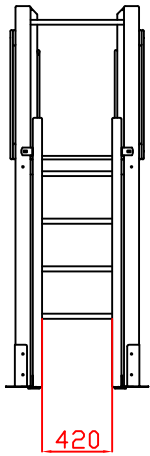

Alzado

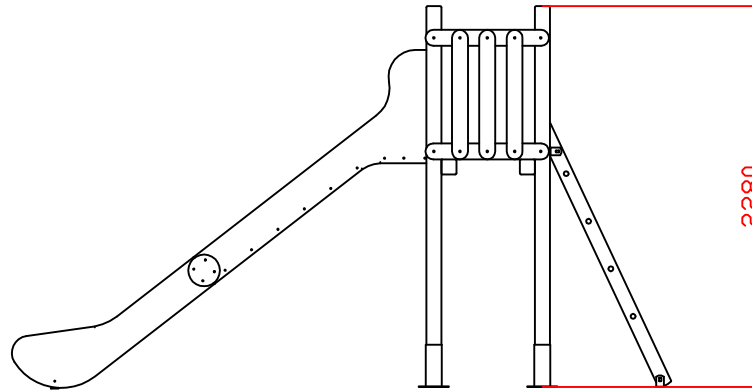

Perfil Izquierdo

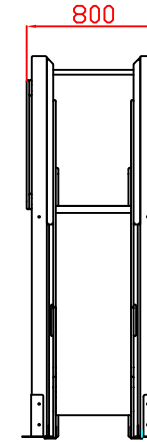

Planta

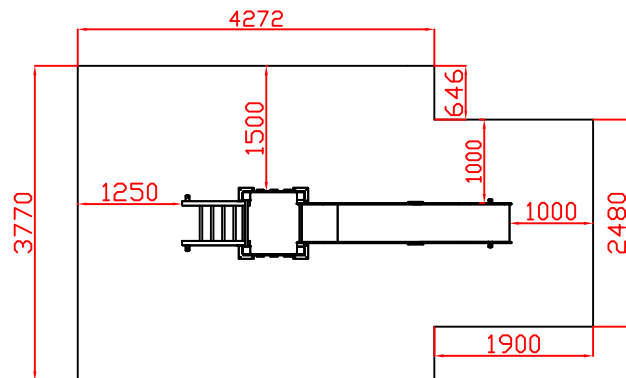
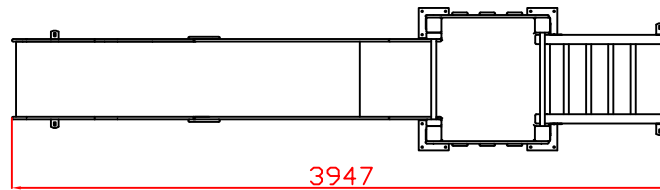

Zona de Seguridad

Superficie= 20,81 m2  
E 1/2

Ref:	Cantidad	Designación	Material	Dimensiones
Dibujado		PLANO 1 VISTAS GENERALES	Código: TT003	
Revisado				
Aprobado				
Descripción: TORRE GREDOS GRANDE		Escala:	Peso:	
		Fecha:	06-08-15	

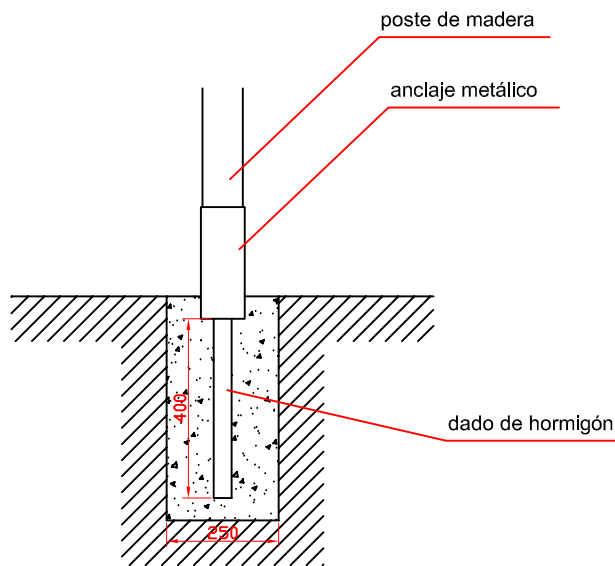
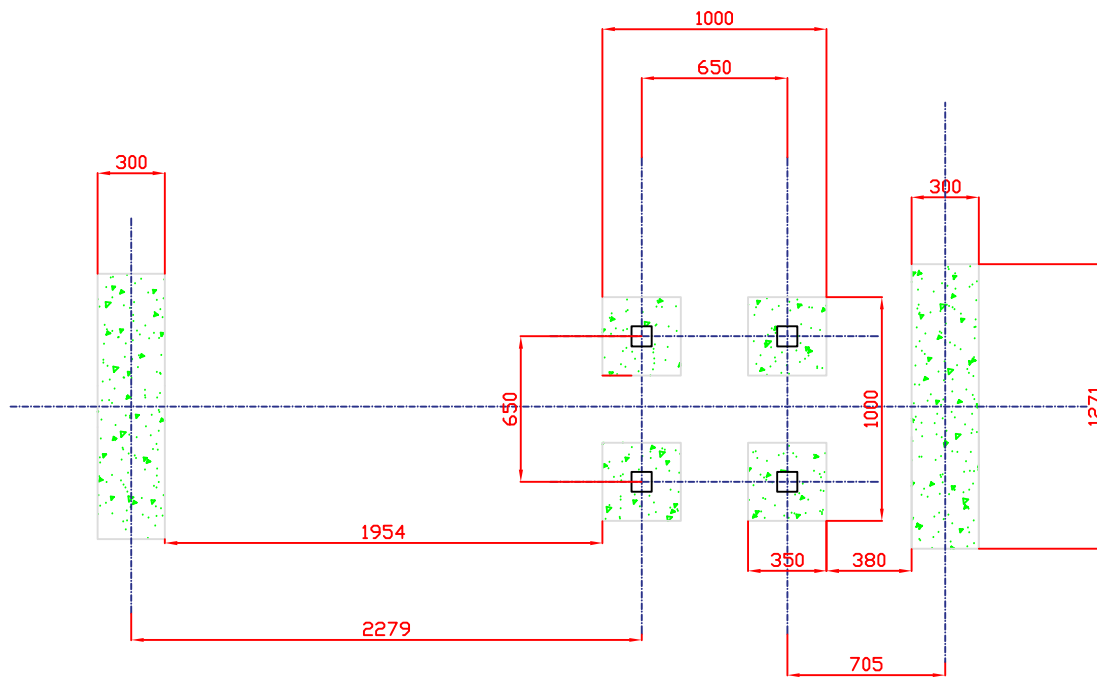

DETALLE DE CIMENTACIÓN  
E:2/1

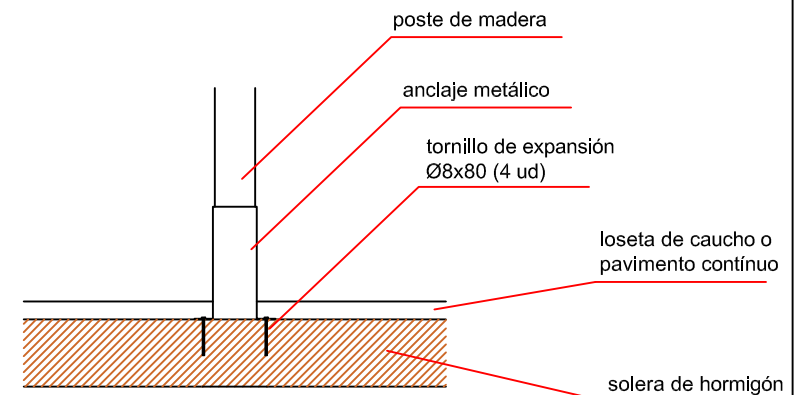

DETALLE DE ANCLAJES  
E:2/1

Ref:CM010	Cantidad	Designación	Material	Dimensiones
Dibujado		PLANO 2 CIMENTACIÓN	Ref.: TT003 	
Revisado				
Aprobado				
Descripción: TORRE GREDOS GRANDE		Escala:	Peso:	
		Fecha: 06/08/15		