

DOCUMENTACIÓN TÉCNICA



Ref.: T007

Tobogán Guadalentín Grande

UNE EN 1176-1:2009

UNE EN 1176-3:2009



marca
acreditada
por



Altura de caída: 1,36 m

Edad recomendada de uso: a partir de 3 años

Componentes plásticos: Polietileno de Alta Densidad con protección UV

Rampa de tobogán: acero inoxidable

Tornillería protegida con tapones de polipropileno

Tubo superior: acero inoxidable

Madera tratada en autoclave Nivel IV

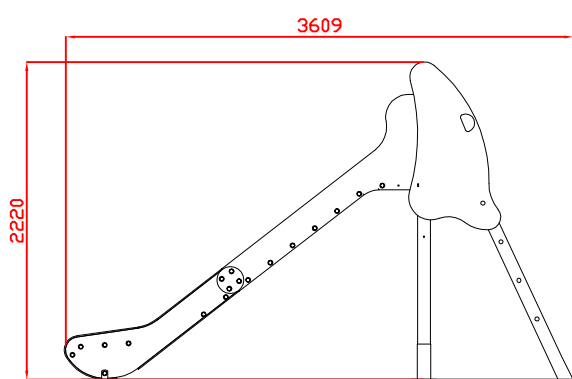

Alzado

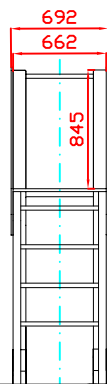

Perfil

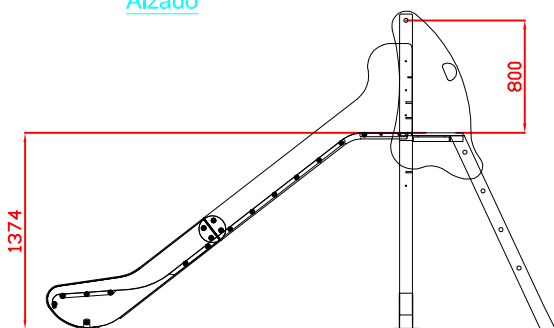

Sección

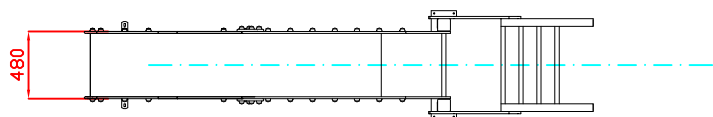

Planta

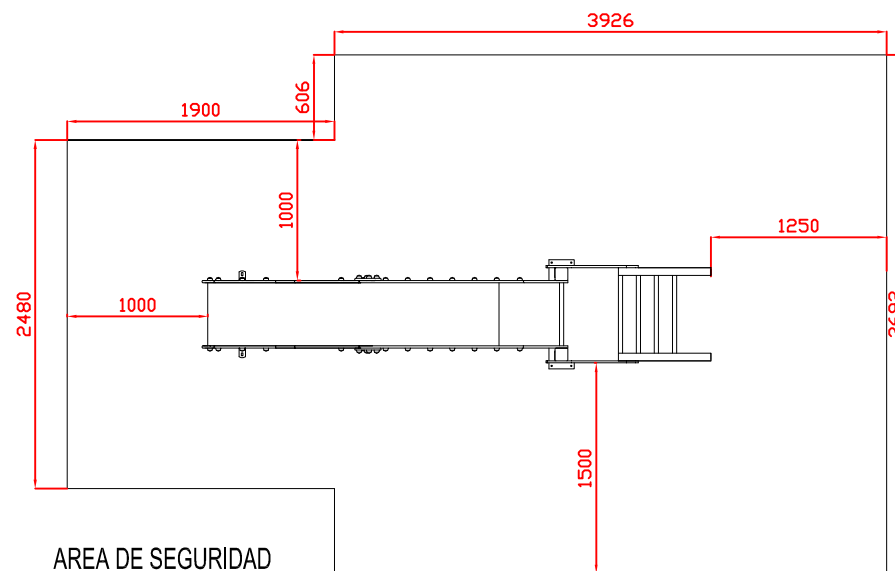

AREA DE SEGURIDAD
Superficie= 19,20 m²

Ref:	Cantidad	Designación	Material	Dimensiones
Dibujado		PLANO 1	Ref.: T007	
Revisado		VISTAS GENERALES		
Aprobado				
Descripción: TOBOGÁN GUADALENTÍN GRANDE		Escala:	Peso:	
		Fecha:	14-08-15	



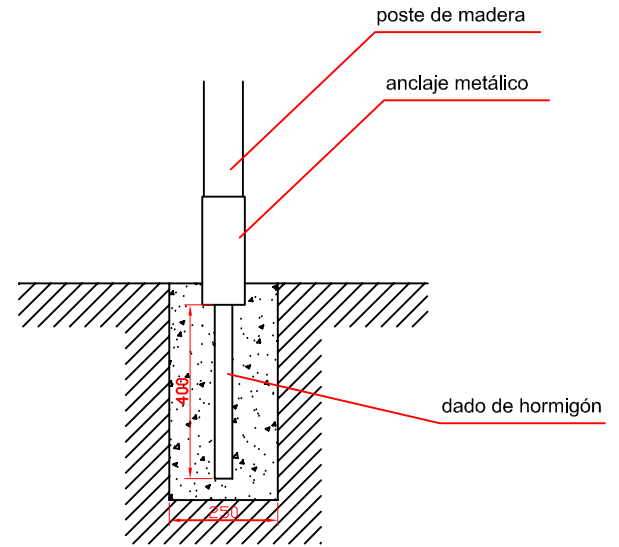
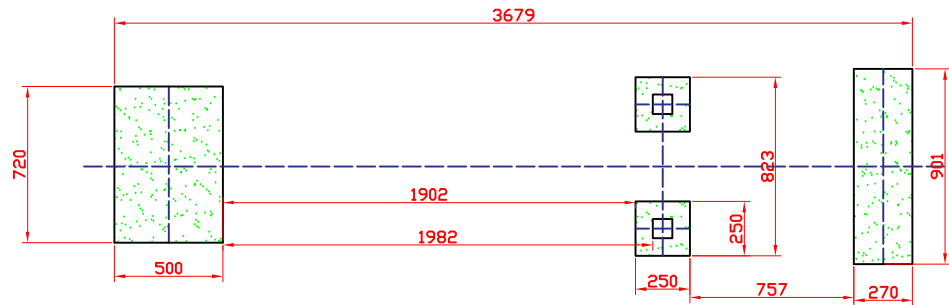

DETALLE DE CIMENTACIÓN
E:2/1

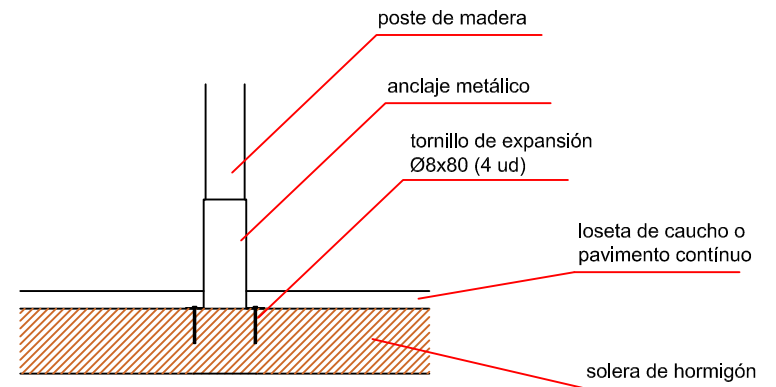

DETALLE DE ANCLAJES
E:2/1

Ref:	Cantidad	Designación	Material	Dimensiones
Dibujado		PLANO 2 CIMENTACIÓN DETALLE DE ANCLAJE	Ref.: T007	
Revisado				
Aprobado				
Descripción: TOBOGÁN GUADALENTIN GRANDE		Escala:	Peso:	
		Fecha: 14-08-15		

