

DOCUMENTACIÓN TÉCNICA

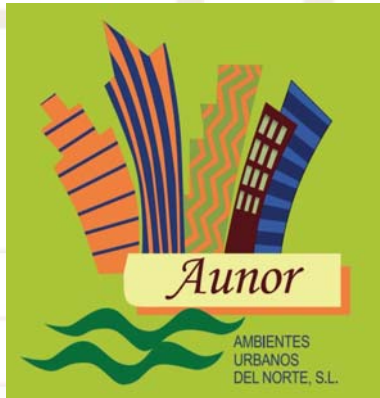

Ref.: CM010

Conjunto "Guadiana"

UNE EN 1176-1:2009

UNE EN 1176-3:2009



Altura libre de caída: 1,36 m

Edad recomendada de uso: a partir de 3 años

Madera de pino tratada en autoclave Nivel IV

Componentes plásticos: Polietileno de Alta Densidad con protección UV

Componentes metálicos galvanizados

Tobogán con rampa de acero inoxidable

Trepa de cuerda con alma de acero

Tubos de barrera de acero inoxidable

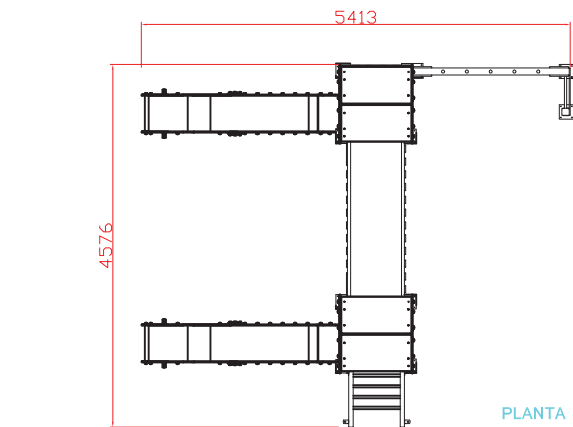
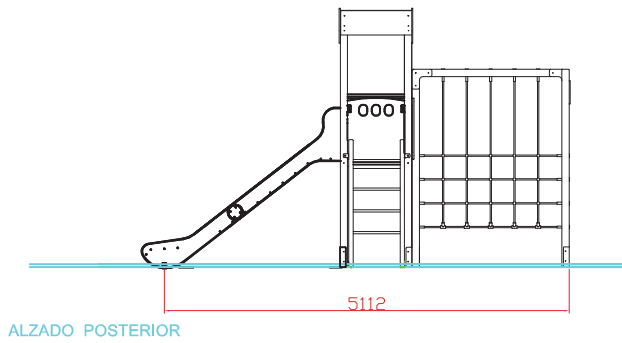
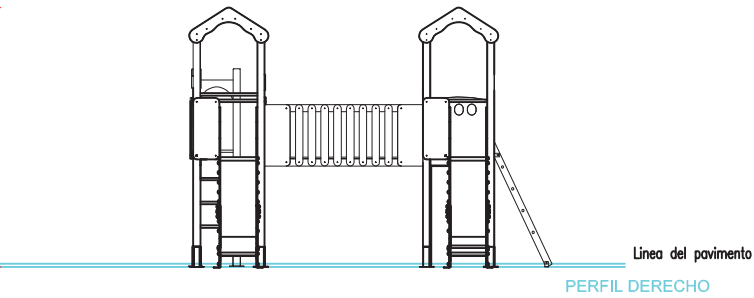
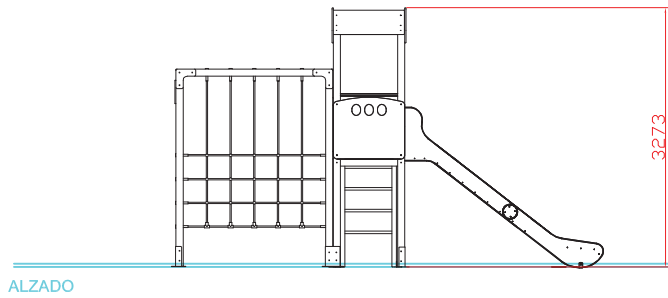

AREA DE SEGURIDAD
SUPERFICIE: 46,56 m²

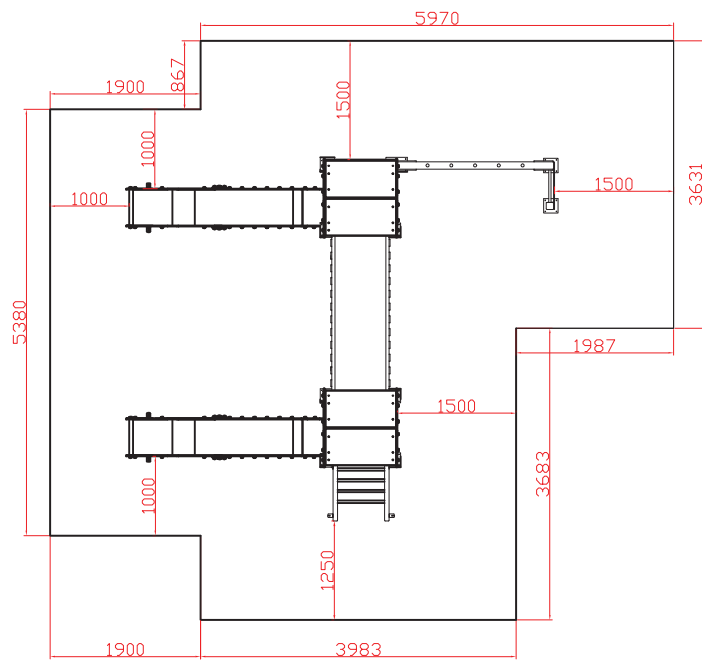

Ref:	Cantidad	Designación	Material	Dimensiones
Dibujado		PLANO 1 VISTAS GENERALES	Ref.: CM010	
Revisado				
Aprobado				
Descripción: CONJUNTO "GUADIANA"		Escala:	Peso:	
		Fecha:	13-08-15	



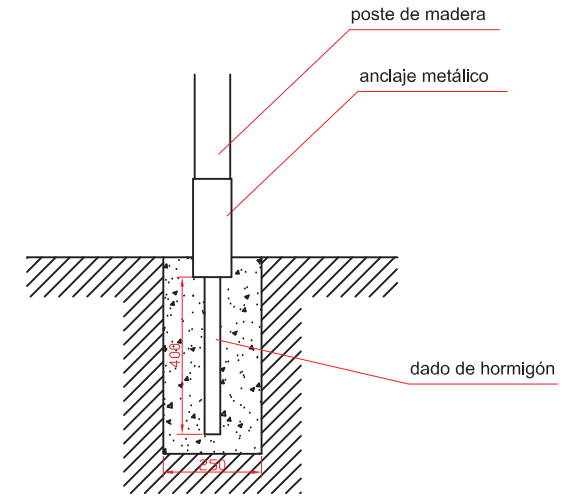
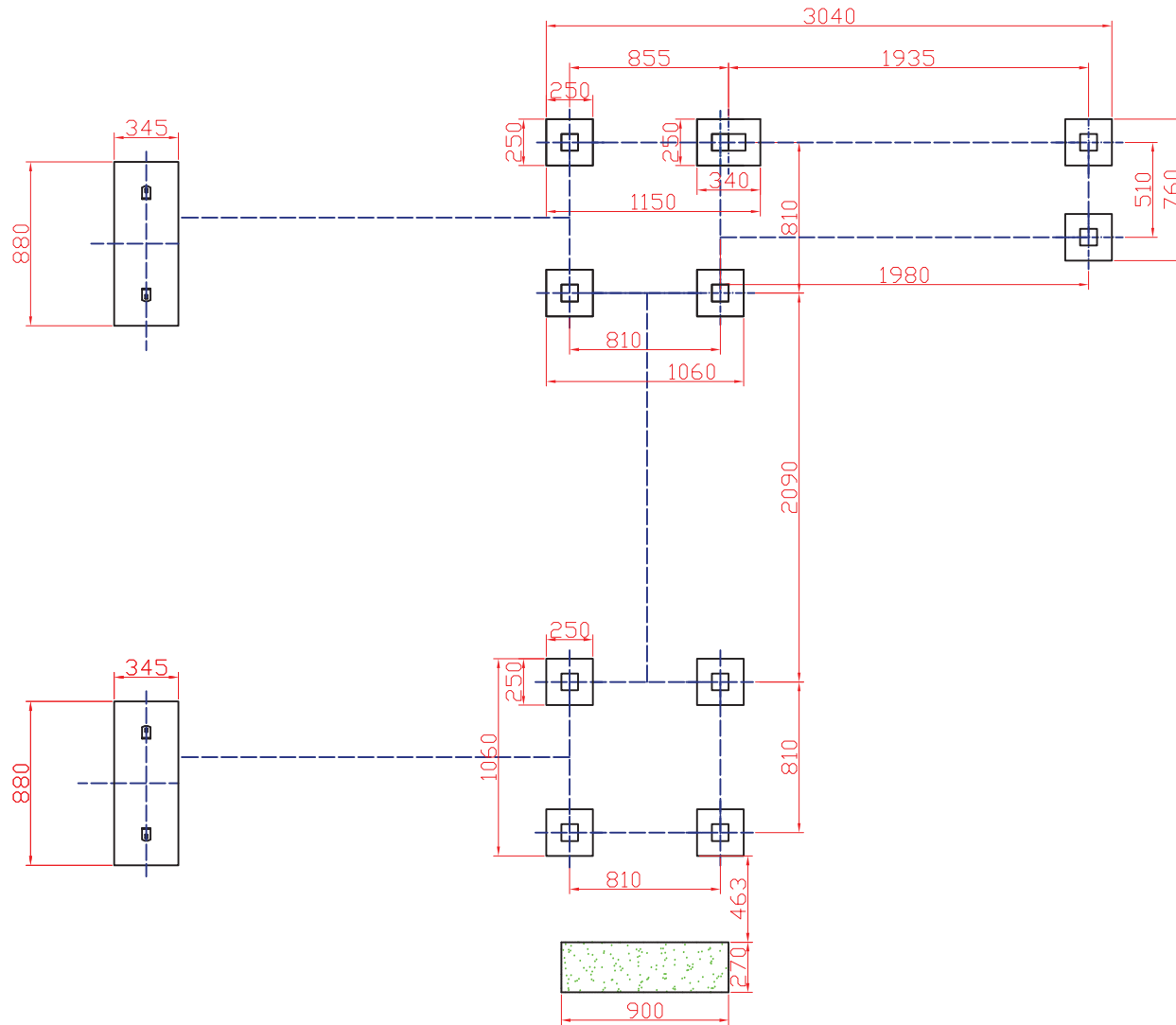

DETALLE DE CIMENTACIÓN
E:2/1

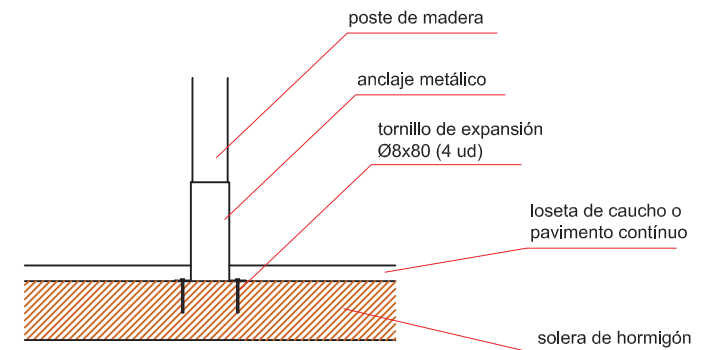

DETALLE DE ANCLAJES
E:2/1

Ref:	Cantidad	Designación	Material	Dimensiones
Dibujado		PLANO 2 CIMENTACIÓN ANCLAJES	Ref.: CM010	
Revisado				
Aprobado				
Descripción: CONJUNTO "GUADIANA"		Escala:	Peso:	
		Fecha:	13-08-15	