

DOCUMENTACIÓN TÉCNICA

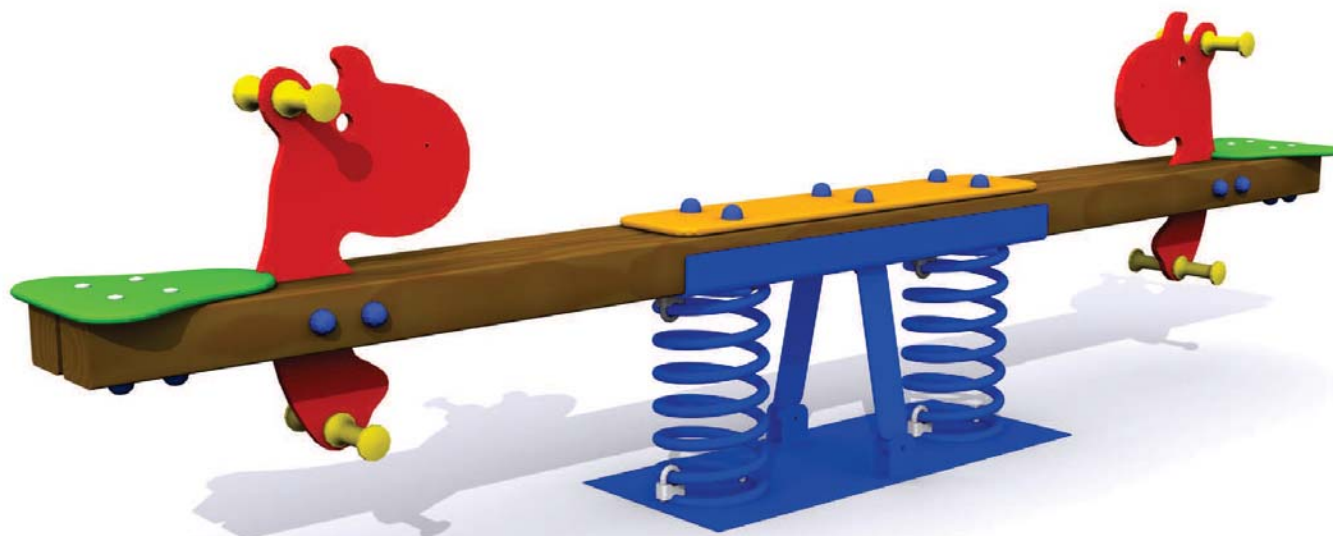
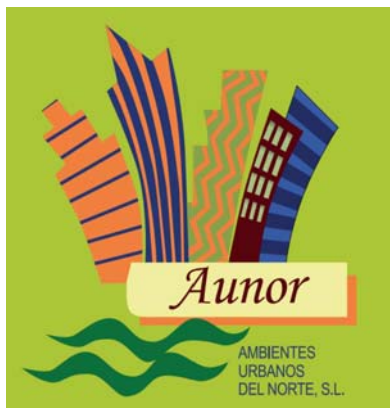

Ref.: BD003

Balancín doble Los Hipopótamos

EN-UNE 1176-1:2009

EN-UNE 1176-6:2009



marca
acreditada
por



Altura libre de caída: 0,50 m
Edad recomendada de uso: de 3 a 9 años
Muelles con antipinzamiento
Componentes metálicos pintados al horno
Madera tratada en autoclave nivel IV
Tornillería protegida con tapones de polipropileno
Componentes plásticos: Polietileno de Alta Densidad
con protección UV

Alzado

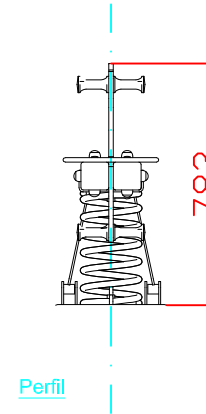
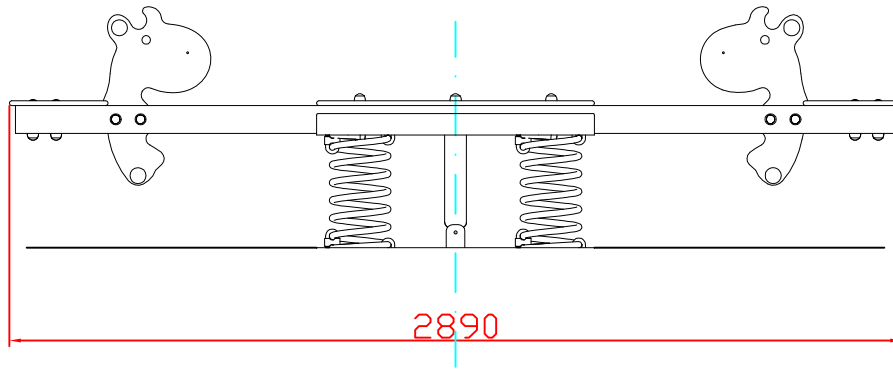

Perfil

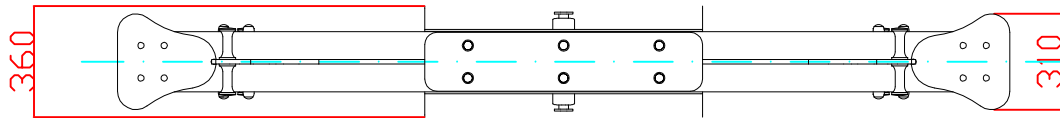

Planta

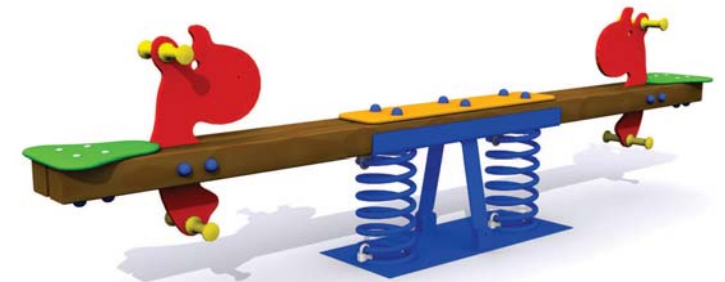

4890

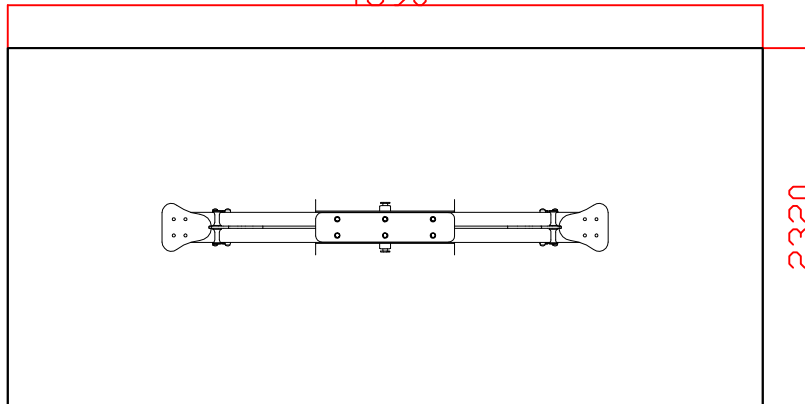

AREA DE SEGURIDAD

Superficie= 11,34 m2

E:1/2

2320

Ref:	Cantidad	Designación	Material	Dimensiones
Dibujado		PLANO 1	Ref.: BD003	
Revisado		VISTAS GENERALES		
Aprobado				
Descripción: BALANCÍN DOBLE LOS HIPOPÓTAMOS		Escala:	Peso:	
		Fecha:	27-07-15	

DETALLE DE CIMENTACIÓN

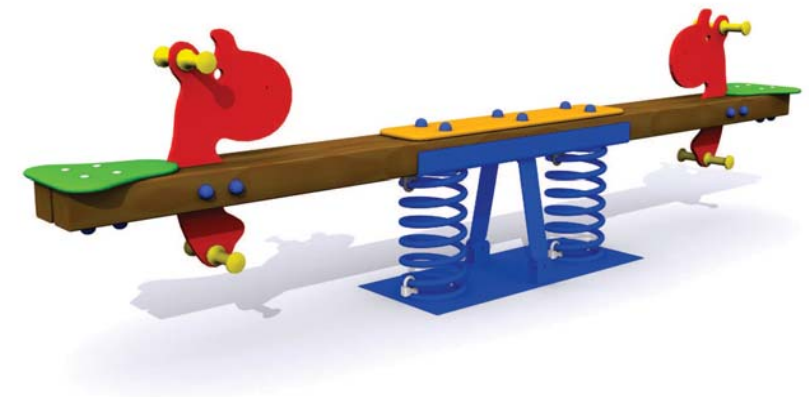
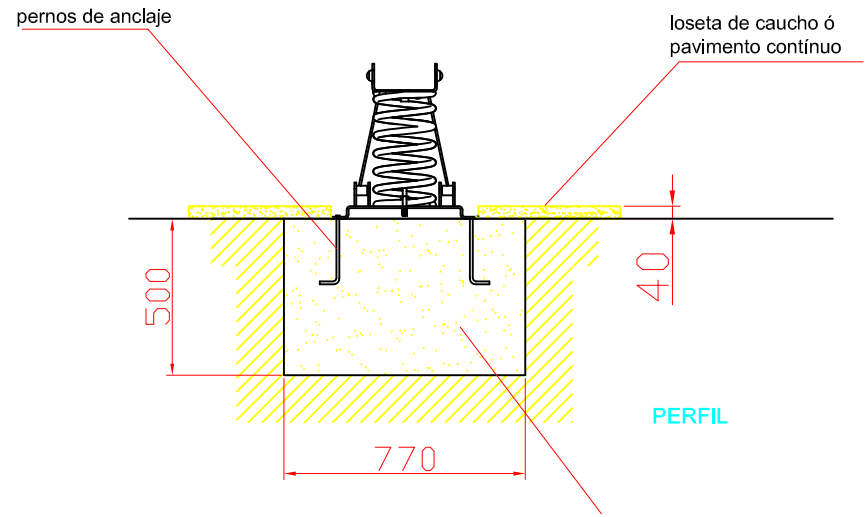
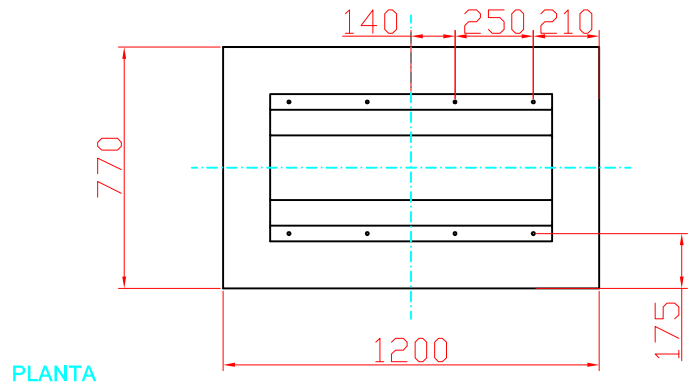
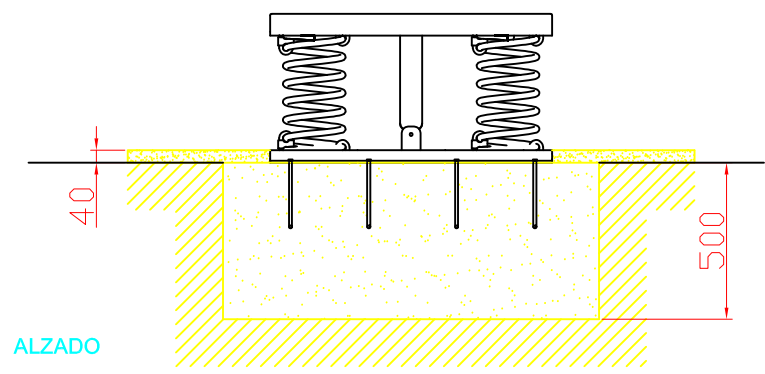

Ref:	Cantidad	Designación	Material	Dimensiones
Dibujado		PLANO 2	Ref.: B0003	
Revisado		PLANO DE CIMENTACIÓN		
Aprobado				
Descripción:	BALANCÍN DOBLE LOS HIPOPÓTAMOS		Escala:	Peso:
			Fecha:	27-07-15