



Certificado EN-1176
EN-1176 Certificate
Certifié EN-1176



+ 6 años

Edad recomendada de uso
Recommended age range
Tranche d'âge recommandée



Carga máxima
Maximum load
Charge maximale



2

Superficie de seguridad
Safer surfacing area
Sol de sécurité

* Estructura	Acero, galvanizado y con revestimiento en polvo <i>Steel, galvanized and powder-coated</i> Structure <i>Structure</i>
* Base de la cesta	Chapa de aluminio corrugada <i>Chequered aluminium plate</i> Base plate <i>Plaque de fond</i> Tôle gaufrée d'aluminium
* Cesta para silla de ruedas	Acero, galvanizado y con revestimiento en polvo <i>Steel, galvanized and powder-coated</i> Car for the wheelchair <i>Cabine pour fauteuil roulant</i> Acier, galvanisé et revêtu par poudre

E

Columpio para personas en silla de ruedas.

El usuario puede columpiarse por sí solo utilizando las cuerdas. Se puede acceder al interior desde el lateral. Dispone de un hueco en la cesta para un ocupante más.
¡ATENCIÓN! Tener en cuenta:
Solo para uso por personas en silla de ruedas.

Columpio para su uso bajo vigilancia de adultos.

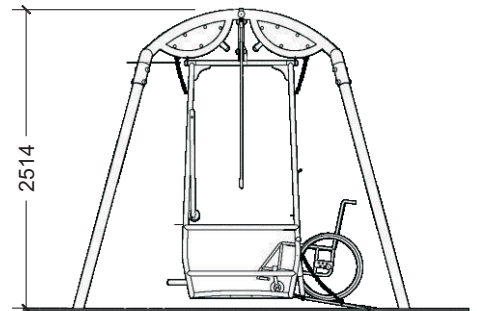

F

*Balanoire pour des personnes en fauteuil roulant.
L'utilisateur peut monter soi-même à l'intérieure par le côté latéral et se balancer soi-même en se servant des cordes pour démarrer et freiner. La cabine dispose d'espace suffisant pour la chaise roulante et un passager de plus.
ATTENTION! Observez:
Uniquement pour utilisation par les personnes en fauteuil roulant.*

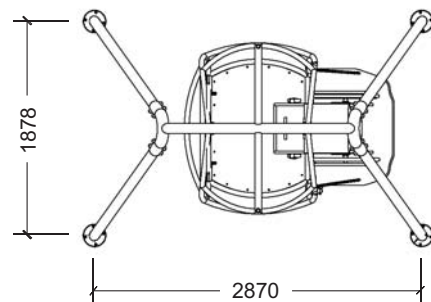

GB

*Wheelchair swing.
The wheelchair user can use the swing on his own without the help of another person: He can board on the swing's car from the side by a ramp and put the swing in motion and decelerate it with the aid of a rope. In the swing's car is enough space for another passenger.
ATTENTION! Please consider:
This wheelchair swing is only for designated use, this means, the*

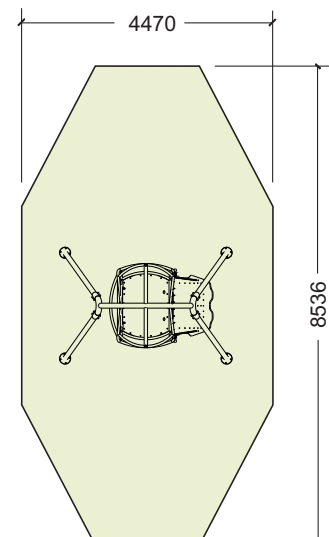



COLUMPIO ADAPTADO
WHEELCHAIR SWING
BALANÇOIRE ACCESIBLE EN FAUTEUIL ROULANT

